

**Caution:**

The plate surfaces on AHP-1200CPV and CCP-22 cascade are precision machined flat surfaces. Do not damage or scratch these surfaces. Ensure they remain clean and free of dust and any other particles.

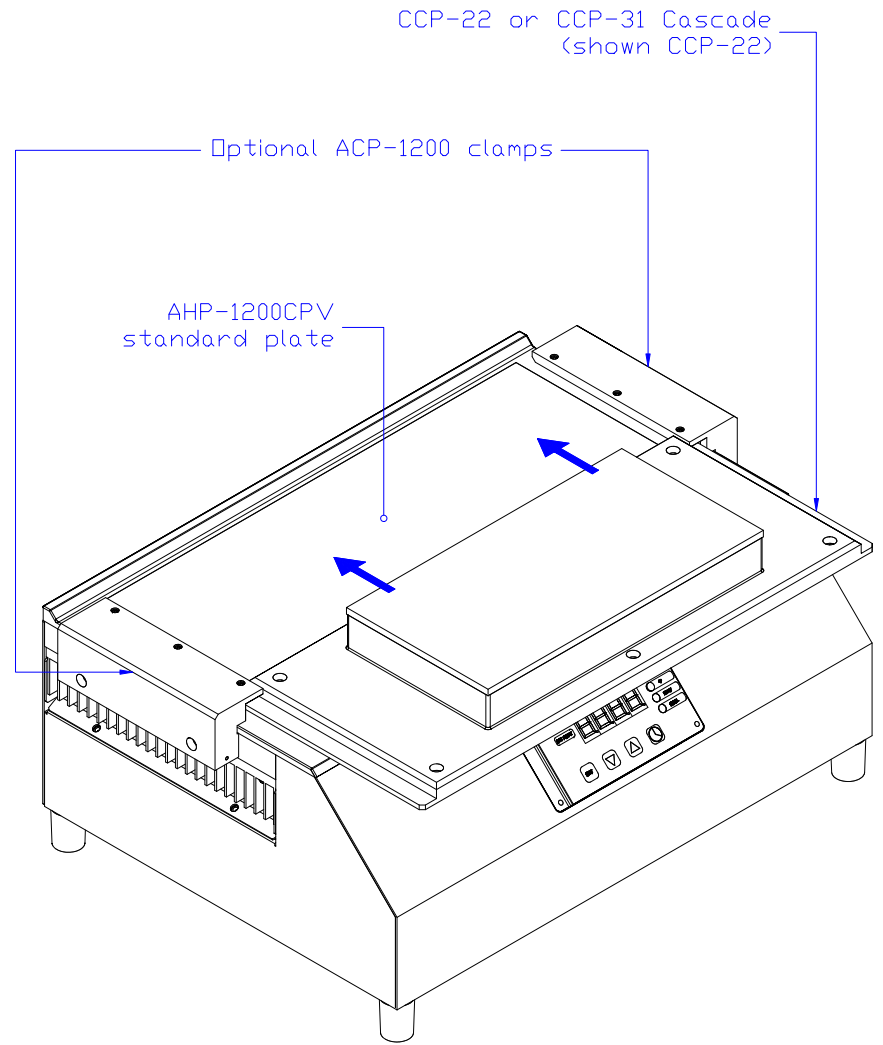
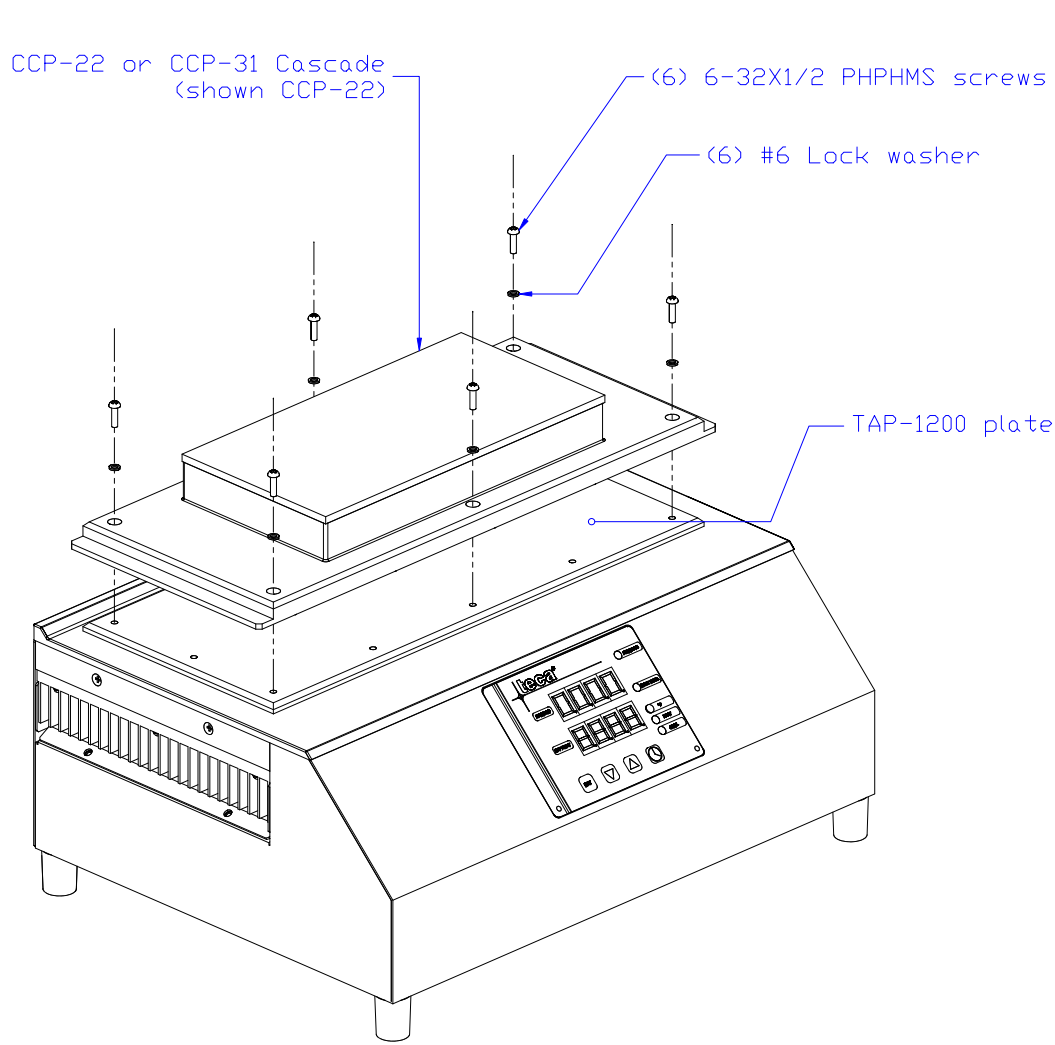

**Installation of CCP-22 or CCP-31 via screws on AHP-1200CPV built with TAP-1200 plate**

**Installation of CCP-22 or CCP-31 via optional ACP-1200 clamps on AHP-1200CPV built with standard plate**

INFORMATION DISCLOSED HEREIN IS THE CONFIDENTIAL PROPERTY OF TECA CORP. RECIPIENT SHALL NOT USE THE INFORMATION IN ANY UNAUTHORIZED MANNER.		UNLESS OTHERWISE SPECIFIED DIMENSIONS ARE IN INCHES TOLERANCES ARE:		<b>THERMOELECTRIC COOLING AMERICA CORP.</b> CCP-22 AND CCP-31 INSTALLATION ON AHP-1200CPV	
		DECIMALS .XX +/- .XXX +/-	ANGLE +/- FRACTION +/-		
FINISH:		MATERIAL:		DRAWN BY: AA	DRAWING # SK080710
				DATE: 07/11/08	REV LEVEL
REV	DESCRIPTION	Date	APPROVED	D7241	SCALE MASTER: SK080312 SHEET