

Product Information Packet

Model AHP-1202XE

NEMA-4 Solid State Air Conditioner

for Remote Temperature Control

Part #0-3052-4-000

Thank you for your purchase. Information has been enclosed regarding the installation, specifications, and wiring of your solid-state assembly. Please read and follow all instructions carefully before installation. Only qualified technicians should install this equipment.

If you have any questions regarding your equipment, please do not hesitate to call us at 773-342-4900, and we will be happy to assist you. We are open from 8:30 am-5:00 pm Central Time.

Included in this packet you will find:

Installation Notes for Air Conditioners

Product Literature and Specifications

Assembly Drawing # 1200-B-A13

Wiring Drawing # 1200-B-E57

Installation Drawing # 1200-A-F57

Warranty Information

The logo for Teca, featuring the word "teca" in a bold, lowercase, sans-serif font. The letter "t" is stylized with a vertical line extending upwards from its stem. The logo is positioned on the left side of the page, above a horizontal line.

ThermoElectric Cooling America Corporation
4048 W. Schubert Avenue • Chicago, IL (U.S.A.) 60639
Ph: 773/342-4900 Fx: 773/342-0191
sales@thermoelectric.com www.thermoelectric.com

Important Installation Notes for Air Conditioners

Mounting Styles: Both 'thru mount' and 'flush mount' units can be positioned in any orientation and on any enclosure surface. It is important to consider interior air flow patterns when determining the mounting location. Also of importance is an unrestricted flow of ambient air thru the hot side heat exchanger. Ease of access and inspection must be considered for those applications in particularly severe environments which may require occasional maintenance.

Vertical (Side/Front/Back) Mounting:

Vertical mounting refers to the vertical direction of the cold side or interior fins and is recommended for applications with high humidity, poor and incomplete cabinet seals or any condition which may cause the cold side fins to be maintained at temperatures below the dew point for long periods of time allowing for the formation of condensation. The vertical fin direction provides a drip path whereupon condensation can be collected via a moisture removal system (standard on FHP-units) or a drip pan positioned below the cold side fins. Drip pans are optional for thru mount units.

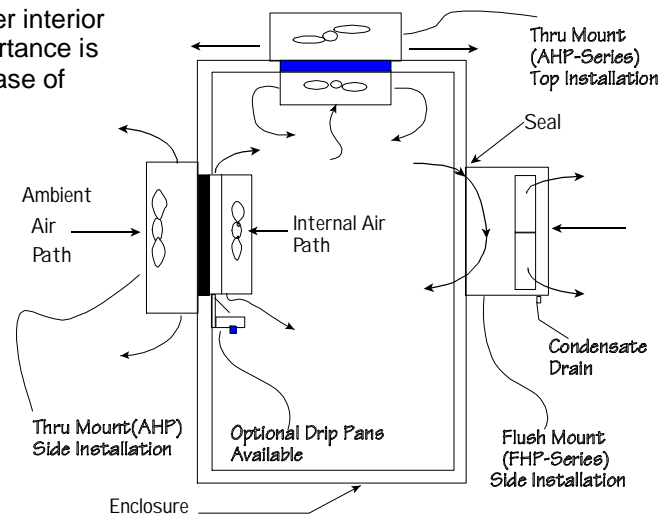

Condensate Removal System:

All FHP-Series and AHP-1400 air conditioners contain a built-in condensate removal system. The condensate kit consists of an antifungal sponge with a condensate wick. PVC tubing is also provided for drainage. Drip pans are optional for thru mount units which must be evaluated on an individual basis. Equations defining a relationship between the cold side fin and enclosure temperatures are provided to assist in the evaluation.

Top Mounting:

Though often the easiest location to mount it is often the most difficult to protect from condensation in this orientation due to the fin orientation, gravity and any susceptible components below. If a drip pan is employed by the end user use caution to place the pan far enough away from the internal fan to minimize the restriction of air flow. The pan should cover the fin ends as well as the fan area. When there is a choice, the vertical orientation is preferred by most users.

Maintenance:

Since the technology is solid-state, there are no filters, compressors, or fluorocarbons to maintain. The only moving parts are the fans. It is recommended for harsh or dirty environments that the heat sinks be cleaned from time to time. This can be accomplished by directing compressed air over the external fins or on NEMA 4 versions by hosing the unit down. This will increase the overall life and performance of the system.

Cautions:

Take care when mounting not to damage the seal between the hot and cold side sinks. Do not attempt to mount a unit to a warped surface or try to make the units mounting surface conform to an unflat surface. Do not pinch or damage any leads when mounting. Do not over tighten any installation screw, use reasonable force. Always mount with any condensate drain down. Do not compress the cold side between the hot side and any other surface. Do not obstruct the airflow on either side. When mounting consider the natural air flows of the enclosure. Connect power only after the installation is complete.

Notes on condensation:

Condensation occurs at the cold side fins when the surface temperature goes below the dew point. To reduce or remove condensate, consider the following:

- Regulate the Fin Temperature above the Dewpoint.
- Keep Enclosure Closed and Sealed from Outside Humidity.
- Use Desiccant (Moisture absorbing Granules.)
- Employ Condensate Removal System/Drip Pans.

If you have any questions regarding your installation, Please feel free to contact our technical department for assistance at 773-342-4900.

AHP-1200

Solid-State Air Conditioner



Air Cooled
Thru Mount
Nema-12, 4,4X, Class 1 Div 2



FEATURES

- Compact, (only 15" L X 7.35" W X 8.17" D)
- Weighs only 21 lbs. (9.5 kg)
- Excels in high ambient temperatures
- Environmentally safe
- Dual voltage versions available
- No compressor, fluorocarbons or filters
- Virtually maintenance-free operation
- Stainless steel exterior housing
- Versions to withstand corrosive environments, shock and vibration
- Mounts and operates in any orientation

INCLUDES

- Adjustable temperature control
- Gasket and mounting hardware
- Power input line cord

APPLICATIONS

Cools electronic enclosures and control cabinets in factories, mines and on ships.

SPECIFICATIONS

	MODEL	PART NUMBER	NOTES	PERFORMANCE RATING BTU/HR	VOLTAGE VAC 50/60HZ	CURRENT AMPS.	WEIGHT LBS.(KG)	TEMP. CONTROL *	OPERATING AMBIENT °C	AGENCY APPROVALS (ETL)
NEMA 12	→ AHP-1200	0-3080-0-000	Cool only	500-550	120	4.0	21(9.5)	TC-6F	-10/+70	UL1995/CSA22.2, CE
	AHP-1200	0-3050-0-000	Cool only	500-550	120	4.0	21(9.5)	OPT*	-10/+70	UL1995/CSA22.2, CE
	AHP-1200HC	0-3030-1-000	Heat/Cool	500-550	120	4.0	21(9.5)	TC-3F	-10/+70	UL1995/CSA22.2, CE
	AHP-1200HC	0-3050-1-000	Heat/Cool	500-550	120	4.0	21(9.5)	OPT*	-10/+70	UL1995/CSA22.2, CE
	AHP-1201	0-3081-0-000	Cool only	500-550	120/240	4.0/2.2	29(13.2)	TC-6F	-10/+70	UL1995/CSA22.2, CE
	AHP-1201	0-3051-0-000	Cool only	500-550	120/240	4.0/2.2	29(13.2)	OPT*	-10/+70	UL1995/CSA22.2, CE
	AHP-1201HC	0-3031-1-000	Heat/Cool	500-550	120/240	4.0/2.2	29(13.2)	TC-3F	-10/+70	UL1995/CSA22.2, CE
	→ AHP-1201HC	0-3051-1-000	Heat/Cool	500-550	120/240	4.0/2.2	29(13.2)	OPT*	-10/+70	UL1995/CSA22.2, CE
	→ AHP-1200XE	0-3080-4-000	Cool only	500-550	120	4.5	23(10.4)	TC-6F	-28/+70	UL1995/CSA22.2, CE
	AHP-1200XE	0-3050-4-000	Cool only	500-550	120	4.5	23(10.4)	OPT*	-28/+70	UL1995/CSA22.2, CE
	AHP-1200XEHC	0-3030-5-000	Heat/Cool	500-550	120	4.5	23(10.4)	TC-3F	-28/+70	UL1995/CSA22.2, CE
	AHP-1200XEHC	0-3050-5-000	Heat/Cool	500-550	120	4.5	23(10.4)	OPT*	-28/+70	UL1995/CSA22.2, CE
NEMA 4X	AHP-1202XE	0-3082-4-000	Cool only	500-550	240	2.5	30(13.6)	TC-6F	-28/+70	UL1995/CSA22.2, CE
	AHP-1202XE	0-3052-4-000	Cool only	500-550	240	2.5	30(13.6)	OPT*	-28/+70	UL1995/CSA22.2, CE
	AHP-1202XEHC	0-3032-5-000	Heat/Cool	500-550	240	2.5	30(13.6)	TC-3F	-28/+70	UL1995/CSA22.2, CE
	AHP-1202XEHC	0-3052-5-000	Heat/Cool	500-550	240	2.5	30(13.6)	OPT*	-28/+70	UL1995/CSA22.2, CE
	AHP-1200X	0-3080-2-000	Cool only	500-550	120	4.0	23(10.4)	TC-6F	-28/+70	UL1995/CSA22.2, CE
	AHP-1200X	0-3050-2-000	Cool only	500-550	120	4.0	23(10.4)	OPT*	-28/+70	UL1995/CSA22.2, CE
	AHP-1200XHC	0-3030-3-000	Heat/Cool	500-550	120	4.0	23(10.4)	TC-3F	-28/+70	UL1995/CSA22.2, CE
	→ AHP-1200XHC	0-3050-3-000	Heat/Cool	500-550	120	4.0	23(10.4)	OPT*	-28/+70	UL1995/CSA22.2, CE
	→ AHP-1200XP	0-3080-2-003	Cool only	500-550	120	4.5	23(10.4)	TC-6F	-28/+70	UL-1604
	AHP-1200XPM	0-3080-2-004	Cool only	500-550	120	4.5	23(10.4)	TC-6F	-28/+70	UL-1604
	→ AHP-1200XPHC	0-3030-3-007	Heat/Cool	500-550	120	4.5	23(10.4)	TC-3F	-28/+70	UL-1604

Consult us for model AHP-1200XM, full shock and vibration version

*OPT; Unit is set up for TC-3300 Controller (or similar)

AHP-1200

PERFORMANCE CURVE

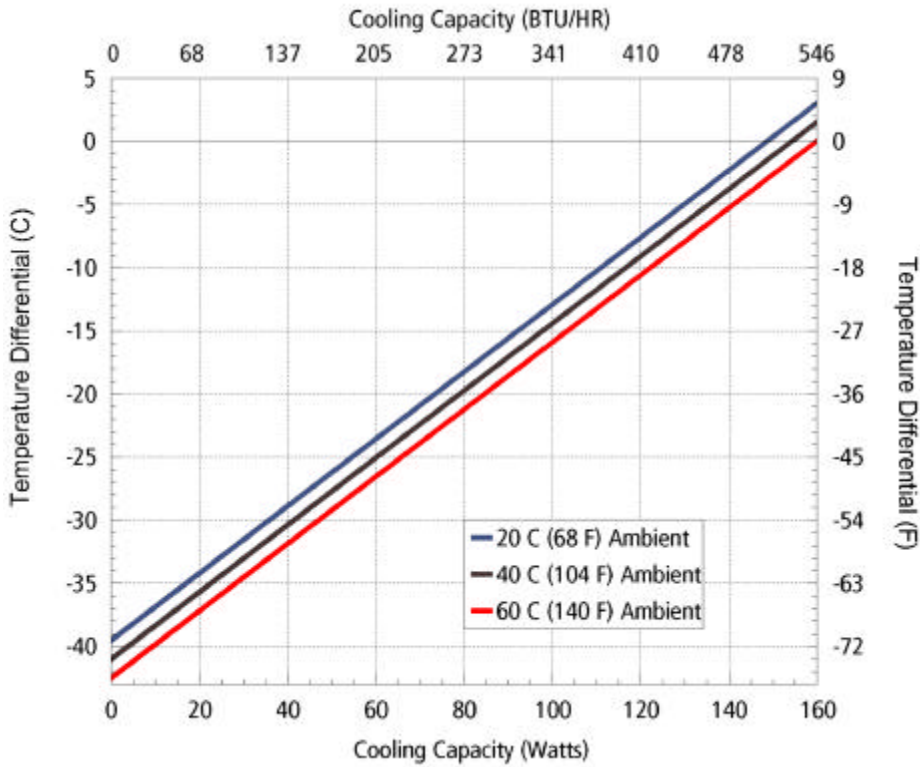

Equation of line: $y = \Delta T(^{\circ}C)$ $x = \text{Capacity (Watts)}$			
Ambient Temp	20°C	40°C	60°C
Enclosure Air	$y = .266x - 39.5$	$y = .266x - 41.0$	$y = .266x - 42.5$
Cold Sink	$y = .173x - 39.5$	$y = .173x - 41.0$	$y = .173x - 42.5$

MOUNTING STYLE

Thru Mount

ENVIRONMENTS

Nema-12 IP 40 (maintains IP 52)

Nema-4/4X IP 56

Class 1 Div 2 & Nema-4X IP 56

RATING (TRADITIONAL)

530 BTU/hr @ 0 °F ΔT

670 BTU/hr @ +20 °F ΔT *

RATING (DIN 3168)

154 Watts L35 L35

100 Watts L35 L50

* See page 6

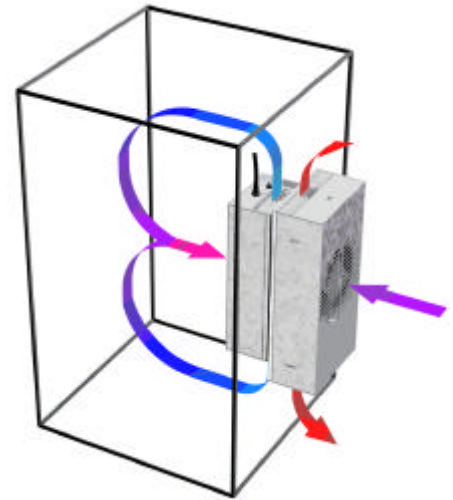

DIMENSIONS

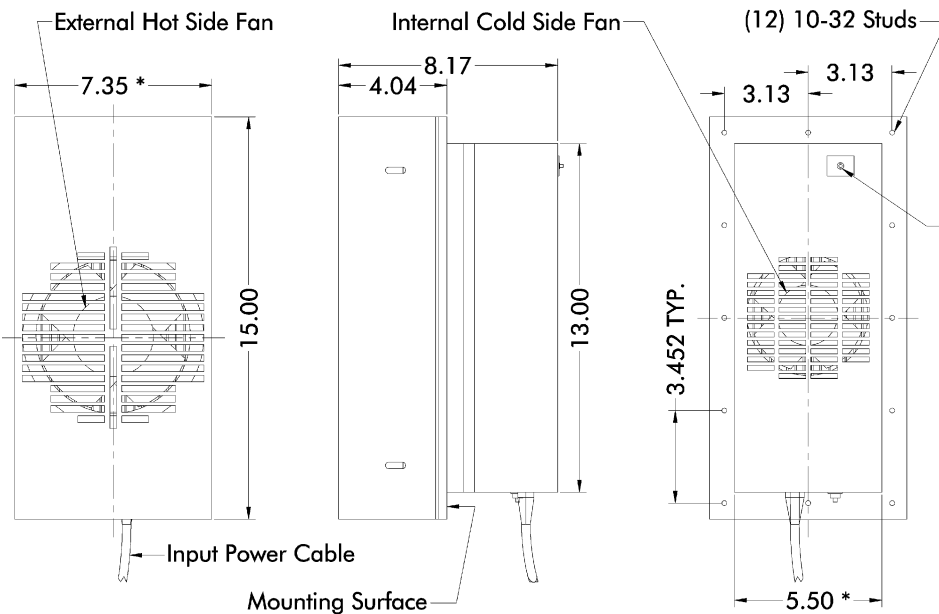

MOUNTING CUTOUT DIMENSIONS

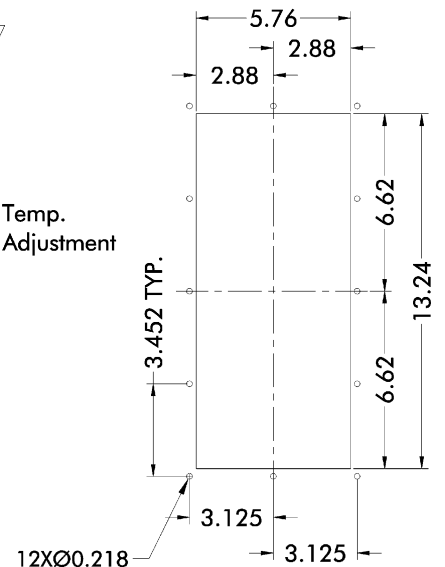

* Dimension does not include hardware. Dimensions: Inches, Mounting hardware and gasket included but not shown.

LTR	DESCRIPTION	DATE	APPROVED
A	CHANGED NUMBER OF STUDS AND DRAWING NUMBER	12-10-88	T. Z.
B	ADD METRIC DIMENSIONS	03.23.90	I.N.

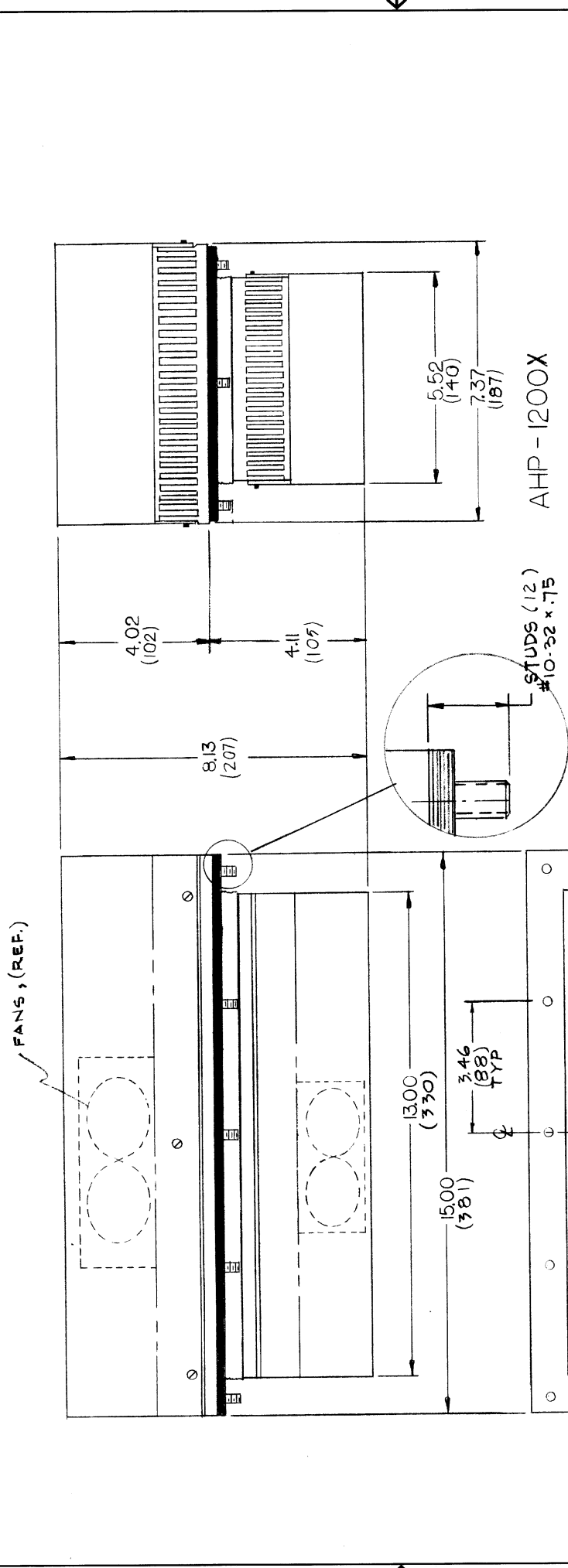

AHP-1200X

NOTE: DIMENSIONS IN INCHES (MILLIMETERS)

 ThermoElectric Cooling America Corp.	
AHP-1200 ASSEMBLY FOR LITERATURE	
UNLESS OTHERWISE SPECIFIED DIMENSIONS ARE IN INCHES TOLERANCES ARE:	
FRACTIONS DECIMALS ANGLES	
± .XX ± .XXX ±	
MATERIAL	
FINISH	
APPROVALS	DATE
DRAWN G.M.	2-11-88
CHECKED	
SIZE	DRAWING NO.
B	1200-B-A13
SCALE 1" = 3/8"	DWTDC
SHEET	OF

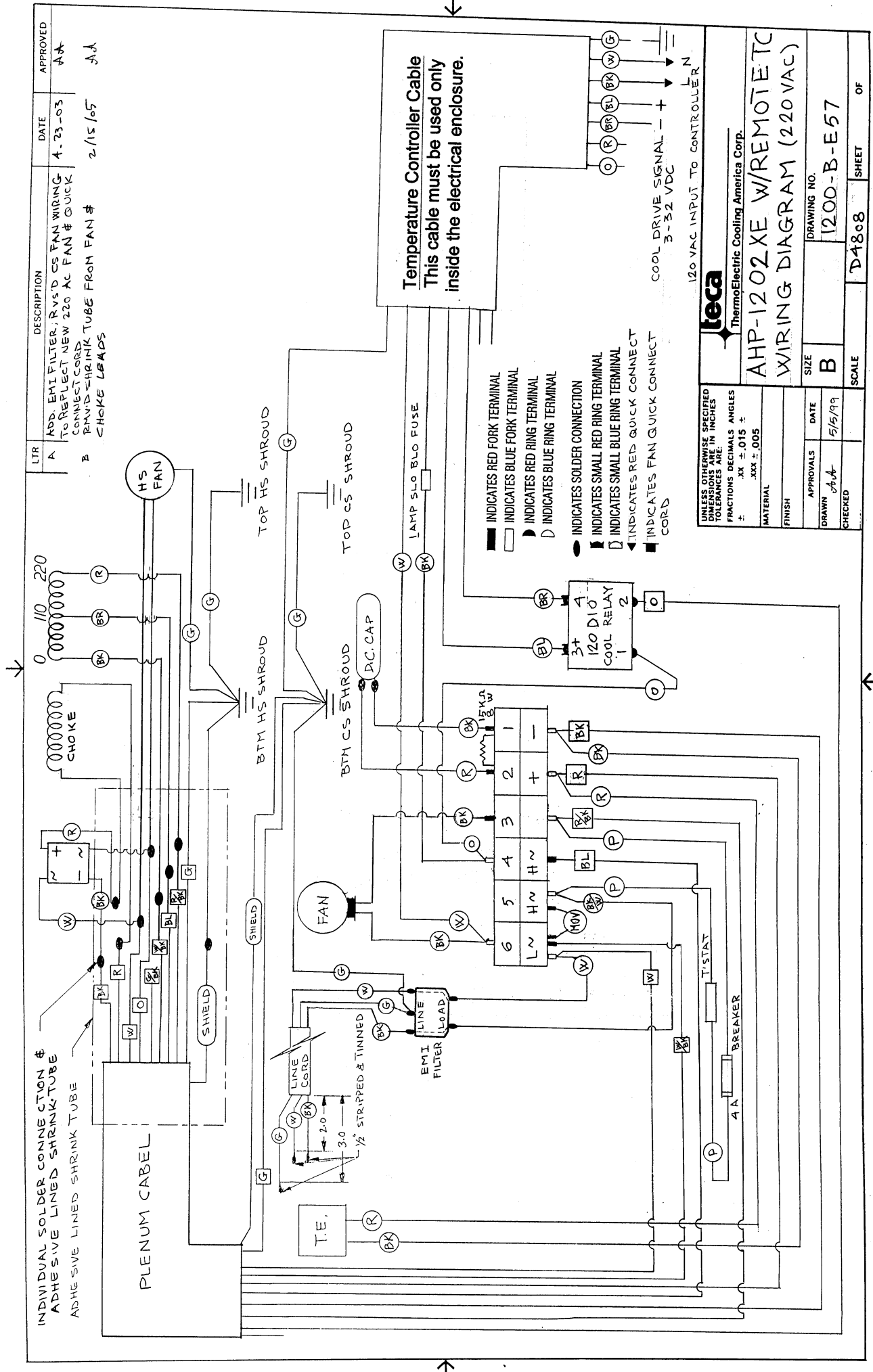

INDIVIDUAL SOLDER CONNECTION & ADHESIVE LINED SHRINK TUBE
ADHESIVE LINED SHRINK TUBE

TR LTR A B

DESCRIPTION
ADD EMI FILTER, RVS'D CS FAN WIRING TO REFLECT NEW 220 AC FAN & QUICK CONNECT CORD
PBAVD-SHRINK TUBE FROM FAN & CHOKE LEADS

DATE
A-23-03
2/15/05

APPROVED
J.A.A.
J.A.A.

Temperature Controller Cable
This cable must be used only inside the electrical enclosure.

- INDICATES RED FORK TERMINAL
- INDICATES BLUE FORK TERMINAL
- INDICATES RED RING TERMINAL
- INDICATES BLUE RING TERMINAL
- INDICATES SOLDER CONNECTION
- INDICATES SMALL RED RING TERMINAL
- INDICATES SMALL BLUE RING TERMINAL
- INDICATES RED QUICK CONNECT CORD
- INDICATES FAN QUICK CONNECT CORD

COOL DRIVE SIGNAL - +
3-32 VDC
120 VAC INPUT TO CONTROLLER L N

UNLESS OTHERWISE SPECIFIED DIMENSIONS ARE IN INCHES TOLERANCES ARE:
FRACTIONS .XX ± .015 ±
.XXX ± .005



ThermoElectric Cooling America Corp.
AHP-1202XE W/REMO TETC
WIRING DIAGRAM (220 VAC)

APPROVALS	DATE	SIZE	DRAWING NO.
J.A.A.	5/5/99	B	1200-B-E57
CHECKED		SCALE	SHEET
		D48c8	OF

Mounting, Montage, Montaggio

Enclosure, Armoire, Gehäuse, Armadi

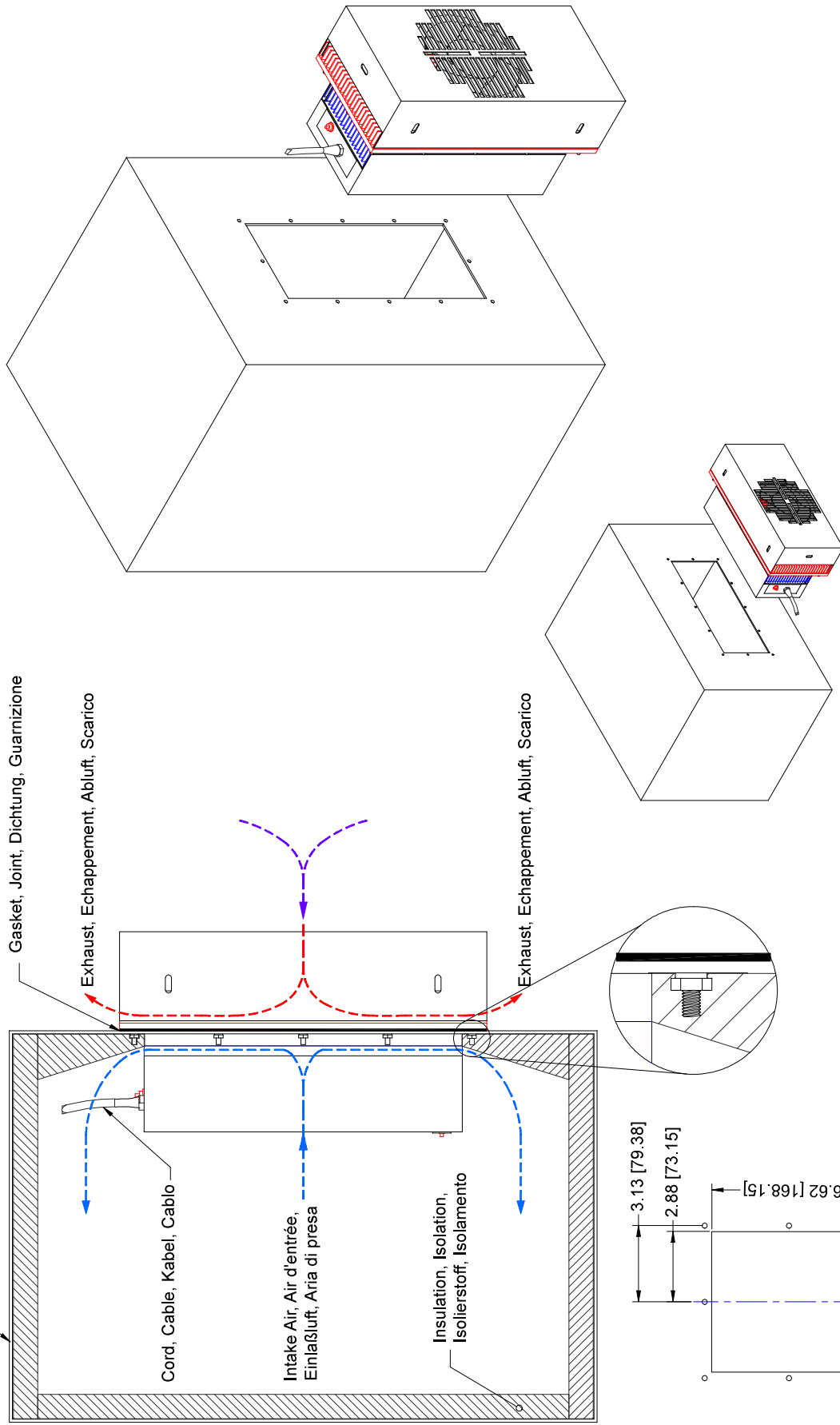

Alternate, Alternative, Alternativa

English, Français, Deutsch, Italiano
Dimensions: Inches [Millimeters]

INFORMATION DISCLOSED HEREIN IS THE CONFIDENTIAL PROPERTY OF TECA CORP. RECIPIENT SHALL NOT USE THE INFORMATION IN ANY UNAUTHORIZED MANNER.	UNLESS OTHERWISE SPECIFIED DIMENSIONS ARE IN INCHES. TOLERANCES ARE: DECIMALS .XX +/- ANGLE +/- FRACTION .XXX+/- MATERIAL:	DRAWN BY:	AA	DRAWING #	1200-A-F57	REV. LEVEL	
		DATE:	05/21/03	SCALE	D6033	MASTER:	MASTER
THERMOELECTRIC COOLING AMERICA CORP.		AHP-1200 SERIES		TYPICAL FIELD MOUNTING			
REV	DESCRIPTION	Date	APPROVED				

LIMITED WARRANTY

In the event a defect in material or workmanship is discovered in any of TECA's products within one year after the date they are delivered to Buyer, and if: (a) TECA is notified of the defect in writing by certified mail within 14 days of the date of discovery; (b) TECA may then either, at its sole discretion, inspect the product at Buyer's location, or require that the product be made available at Buyer's expense at TECA's premises for TECA's inspection within 14 days of the date of notification; and (c) the products are defective and the defects result from faulty materials and/or workmanship and not in any way from accident, misuse, misapplication, mishandling, modification, or alteration by the Buyer or the shipper, then TECA shall, at its sole option, repair or exchange defective products free of charge to Buyer, or credit to buyer the price of the defective products. ALL OTHER WARRANTIES, EXPRESS OR IMPLIED, ARE EXCLUDED, INCLUDING BUT NOT LIMITED TO THE IMPLIED WARRANTIES OF MERCHANTABILITY AND FITNESS FOR A PARTICULAR PURPOSE. IN NO EVENT SHALL TECA BE LIABLE FOR ANY CLAIM BASED UPON BREACH OF EXPRESS OR IMPLIED WARRANTY OR ANY OTHER DAMAGES WHETHER SPECIAL, INDIRECT, INCIDENTAL, CONSEQUENTIAL, LOST PROFITS, BUSINESS INTERRUPTION, OR LOSS OF BUSINESS OR CUSTOMER RELATIONSHIPS.

RETURNED GOODS, RESTOCKING CHARGES

In order to return merchandise for any reason (repair, replacement, or credit) a return authorization number must be issued by TECA. New merchandise may not be returned for credit beyond 60 days from shipment. Charges for incidental or other damages may also be made. All returned goods must be sent freight prepaid. A restocking charge of 15% will apply. On special equipment and custom modified equipment orders, additional incremental cancellation charges may be made.