

Product Information Packet

Model AHP-1 200XP

NEMA 4-X, Class 1 Div 1, Solid State Air Conditioner

for Remote Temperature Control

Part #0-3070-2-018

Thank you for your purchase. Information has been enclosed regarding the installation, specifications, and wiring of your solid-state assembly. Please read and follow all instructions carefully before installation. Only qualified technicians should install this equipment.

If you have any questions regarding your equipment, please do not hesitate to call us at 773-342-4900, and we will be happy to assist you. We are open from 8:30 am-5:00 pm Central Time.

Included in this packet you will find:

Installation Notes for Air Conditioners

Vortex Air Amplifier Notes

Assembly Drawing # 1200-B-A232

Wiring Drawing # 1200-B-E78

Mounting Cut Out Dimension

Warranty Information

The logo for Teca, featuring the word "teca" in a bold, lowercase, sans-serif font. The letter "t" is stylized with a vertical line extending upwards from its stem. The logo is positioned on the left side of the page, above a horizontal line.

ThermoElectric Cooling America Corporation
4048 W. Schubert Avenue • Chicago, IL (U.S.A.) 60639
Ph: 773/342-4900 Fx: 773/342-0191
sales@thermoelectric.com www.thermoelectric.com

Important Installation Notes for Air

Mounting Styles: The only recommended mounting orientation for this product is vertical mounting with the compressed air input fitting looking downward as shown in the sketch. It is important to consider interior air flow patterns when determining the mounting location. Also of importance is an unrestricted flow of ambient air thru the hot side heat exchanger. Ease of access and inspection must be considered for those applications in particularly severe environments which may require occasional maintenance.

Vertical (Side/Front/Back) Mounting:

Vertical mounting refers to the vertical direction of the cold side or interior fins and is recommended for applications with high humidity, poor and incomplete cabinet seals or any condition which may cause the cold side fins to be maintained at temperatures below the dew point for long periods of time allowing for the formation of condensation. The vertical fin direction provides a drip path whereupon condensation can be collected via a moisture removal system (standard on FHP-units) or a drip pan positioned below the cold side fins. Drip pans are optional for thru mount units.

Compressed air supply:

A) In order for this product to function, sufficient amount of compressed air must be supplied through the 3/8 NPT fitting to Vortex Air Amplifier. To obtain maximum performance from the Vortex Air Amplifier, accurate measurements of air pressure (psi) and air volume (cfm) must be obtained. Line pressure of 70-90 psi can be present without sufficient volume (scfm) of air. To ensure that both pressure and volume are present to efficiently operate the Vortex Air Amplifier, a line size of 1/4" pipe or 1/2" hose should be used for applications up to 10 feet from the main header. Use 3/8" pipe or 3/4" hose up to 20 feet. and 3/4" pipe or 1" hose up to 50 feet. Do not use coiled hose as the very small inside diameter of the hose limits air flow.

B) Air supplies are plagued with condensed water vapor in the air lines. This condensation leads to rust and dirt in the air lines. Also some compressors will allow oil or oil vapor to enter the lines. Small orifices in the Vortex Air Amplifier may become clogged with the rust dirt, and water droplets. A 5- micron filter will separate 99% of the foreign material from the air supply allowing virtually maintenance free operation. The use of an oil filter will remove the oil droplets with an effective filtration of 0.01 ppm for an even cleaner air supply.

Condensate Removal System:

All FHP-Series and AHP-1400 air conditioners contain a built-in condensate removal system. The condensate kit consists of a antifungal sponge with a condensate wick. PVC tubing is also provided for drainage. Drip pans are optional for thru mount units which must be evaluated on an individual basis. Equations defining a relationship between the cold side fin and enclosure temperatures are provided to assist in the evaluation.

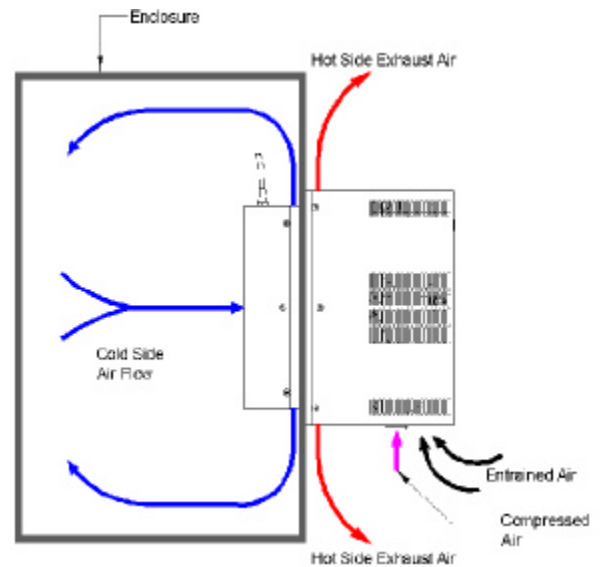

teca[®]

ThermoElectric Cooling America Corporation • 4048 W. Schubert Ave. • Chicago IL (USA) 60639
Phone: 773-342-4900 Fax: 773-342-0191 • www.thermoelectric.com • teca@thermoelectric.com

Maintenance:

Since the technology is solid-state, the maintenance is minimal. The only moving parts are the fans. It is recommended for harsh or dirty environments that the heat sinks be cleaned from time to time. This can be accomplished by directing compressed air over the external fins or on NEMA 4 versions by hosing the unit down. This will increase the overall life and performance of the system.

Cautions:

Take care when mounting not to damage the seal between the hot and cold side sinks. Do not attempt to mount a unit to a warped surface or try to make the units mounting surface conform to an unflat surface. Do not pinch or damage any leads when mounting. Do not over tighten any installation screw, use reasonable force. Always mount with any condensate drain down. Do not compress the cold side between the hot side and any other surface. Do not obstruct the airflow on either side. When mounting consider the natural air flows of the enclosure. Connect power only after the installation is complete.

Notes on condensation:

Condensation occurs at the cold side fins when the surface temperature goes below the dew point. To reduce or remove condensate, consider the following:

- Regulate the Fin Temperature above the dew point.
- Keep Enclosure Closed and Sealed from Outside Humidity.
- Use Desiccant (Moisture absorbing Granules.)
- Employ Condensate Removal System/Drip Pans.

If you have any questions regarding your installation, Please feel free to contact our technical department for assistance at 773-342-4900.

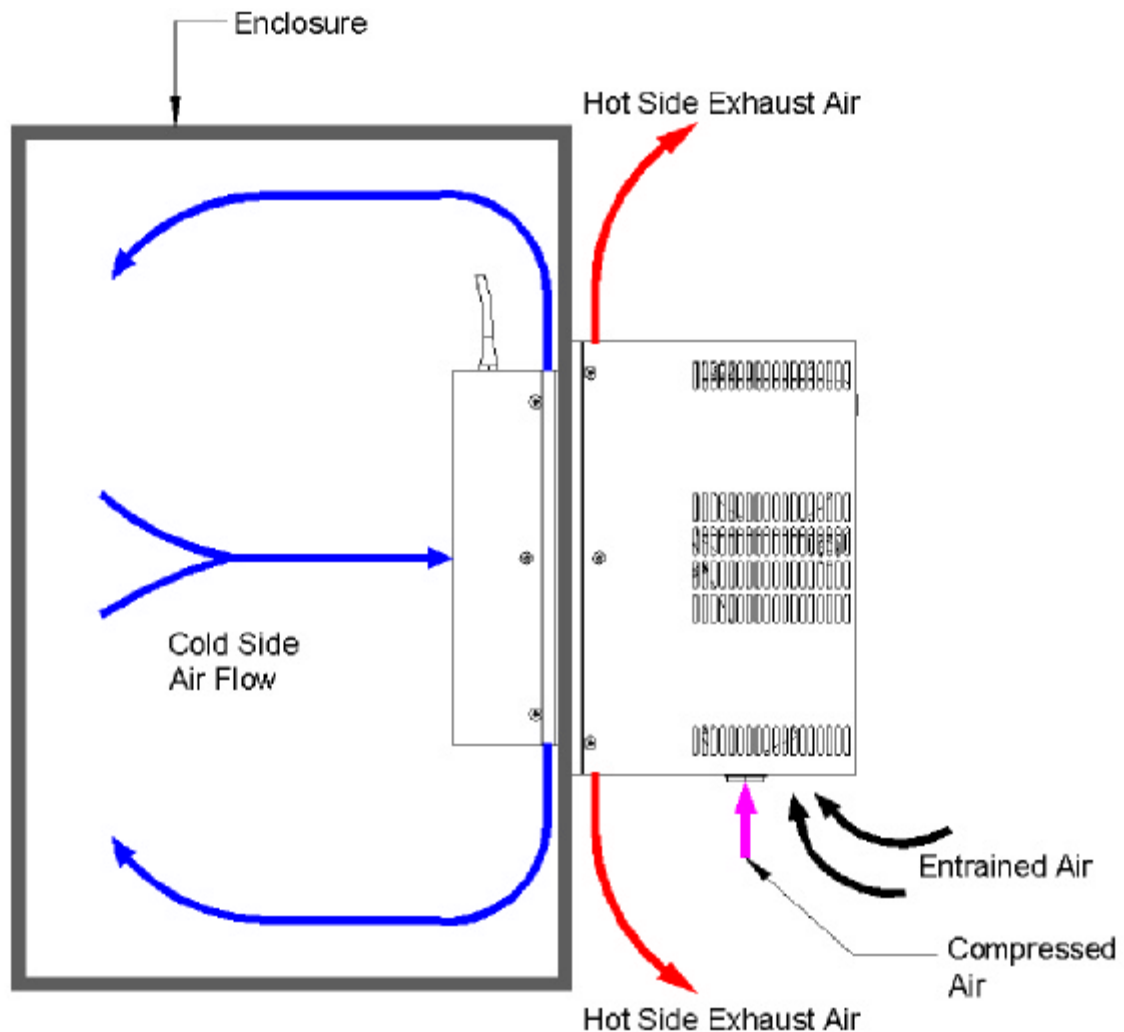

teca[®]

ThermoElectric Cooling America Corporation • 4048 W. Schubert Ave. • Chicago IL (USA) 60639
Phone: 773-342-4900 Fax: 773-342-0191 • www.thermoelectric.com • teca@thermoelectric.com

ARTX AIR AMPLIFIERS, JETS, NOZZLES, AIR CURTAINS

1. COMPRESSED AIR SUPPLY

Air supplies are plagued with condensed water vapor in the air lines. This condensation leads to rust and dirt in the air lines. Also some compressors will allow oil or oil vapor to enter the line.

Small orifices in the ARTX Air Saver products may become clogged with the rust dirt, and water droplets. A 5- micron filter will separate 99% of the foreign material from the air supply allowing virtually maintenance free operation. The use of an oil filter will remove the oil droplets with an effective filtration of 0.01 ppm for an even cleaner air supply.

Air Filter Model 90175 can be used with all ARTX products up to the Air Curtains not longer than 12". Model 90180 can be used for the Air Curtain 12" and longer.

The Oil Filter Model 91175 can be used along with the 90175 air filter for the same ARTX products.

Keep in mind that the current line or air might contain dirt or oil and should be blown out before installation. Also pipe thread sealant or tape must be carefully applied to avoid clogging product orifices.

2. ARTX PRODUCT PERFORMANCE/ COMPRESSED AIR SUPPLY LINE SIZE.

To obtain maximum performance from the ARTX products, accurate measurements of air pressure (psi) and air volume (cfm) must be obtained. Line pressure of 70-90 psi can be present without sufficient volume (scfm) of air. To ensure that both pressure and volume are present to efficiently operate the ARTX products, a line size of 1/4" pipe or 1/2" hose should be used for applications up to 10 ft. from the main header. Use 3/8" pipe or 3/4" hose up to 20 ft. and 3/4" pipe and 1" hose up to 50 feet. For the ARTX Air Curtain above 12", use 1/2" pipe up to 10 ft. from the main header, 3/4" pipe up to 20 ft. and 1" pipe up to 50 feet. Do not use coiled hose as the very small inside diameter of the hose limits air flow. Pipe air into both ends of Air Curtain 18" or more to insure even air flow.

3. USE AND INSTALLATION OF ARTX AMPLIFIERS, AIR SAVER NOZZLES, JETS AND AIR CURTAINS.

All of the ARTX products are easily adjusted for increased or decreased air flow, depending on your particular need. Each setting of the product will produce amplified air flows. The Jets amplify the compressed air flow by 4 times. The Air Amplifiers increase the compressed air volume 12-25 times and the Nozzles and Air Curtains produce air flow 25 times that of the input air.

The Model 48009 and 40009 adjustable Air Saver Nozzles have an Allen head set screw in the end of the nozzle to lock adjustments in place. A 3/32 hex head wrench can be used to turn the adjusting screw.

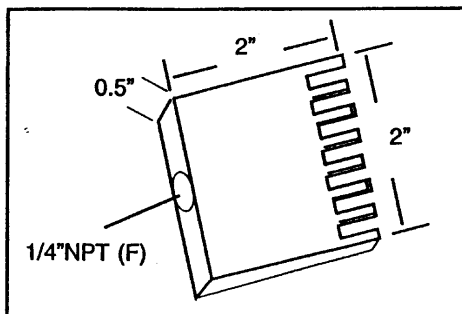

Wedge Model 38050

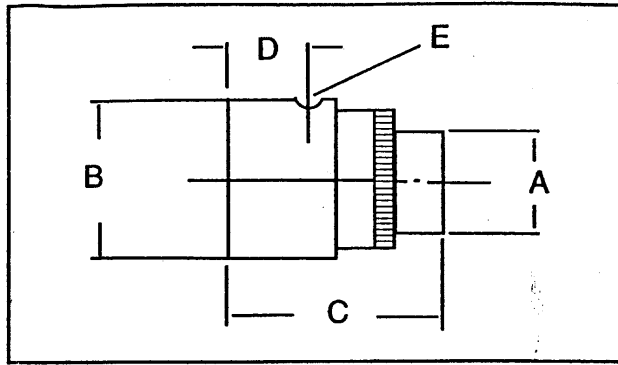

Variable Air Amplifier (see page 42 for dimensions)

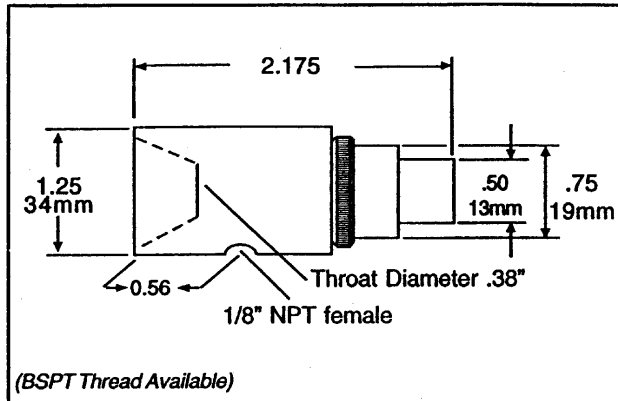

High-Thrust Jet Model 38038

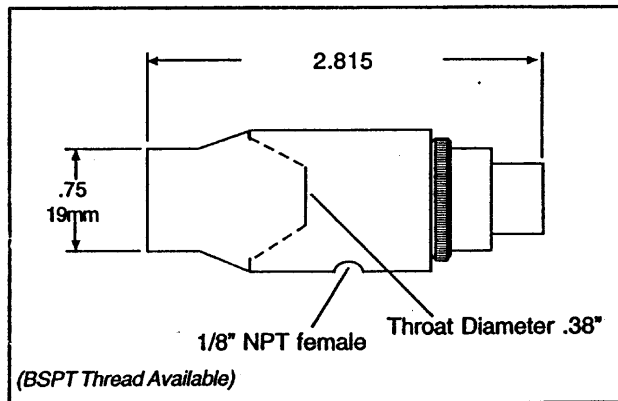

High-Thrust Jet Model 38044

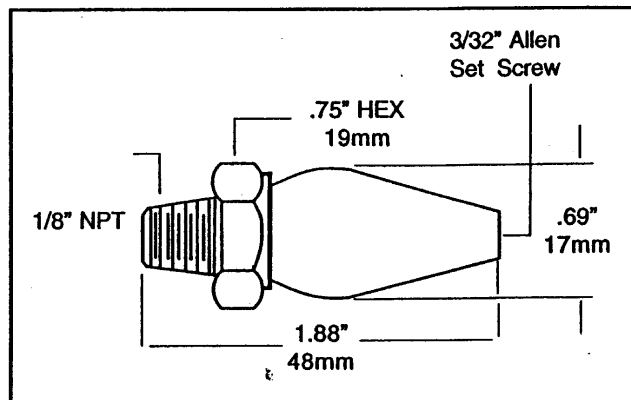

Air Saver Nozzle Model 40009/48009

The Air Curtain require shims placed under the top cap to increase air flow. The standard shim in the unit provides a 0.003" gap for the exit air. Shims are available in 0.003" thickness and can be stacked up to 0.009" to increase flow. The compressed air usage is from 2.3 scfm per inch at 40 psi of air curtain to 4.3 scfm per inch at 80 psi for each shim. Compressed air should be supplied from both ends of the air curtains 18" or longer.

4. MAINTENANCE AND CLEANING

Without moving parts, the ARTX Air Amplifiers, Jets, Air Saver Nozzles and Curtains do not wear. Fluctuation in flow could occur in air lines or orifices that are clogged or if the supply air line is under sized.

All of the ARTX products are easily disassembled for easy cleaning and removal of dirt, rust or contaminants with a solvent and clean rag.

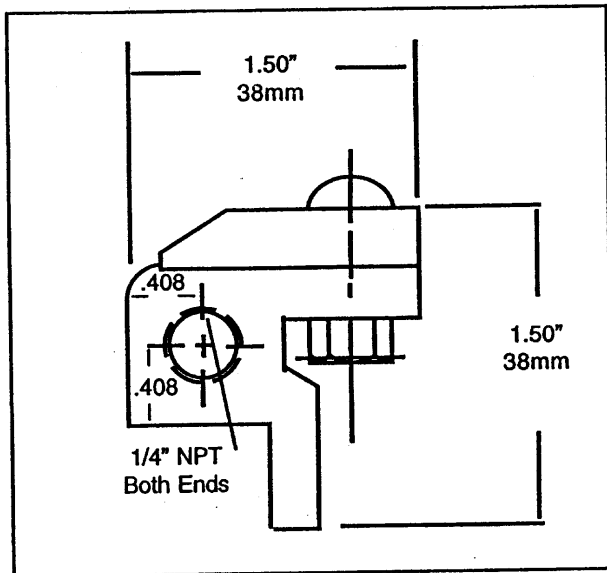

End View Aluminum Air Curtain

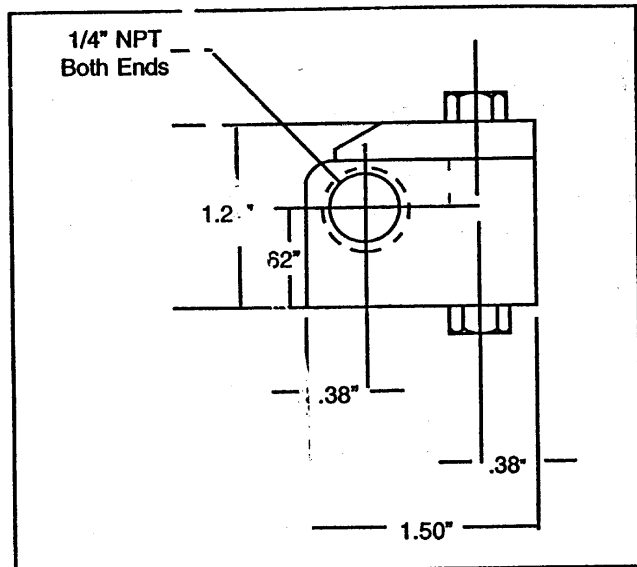

End View Stainless Steel Air Curtain

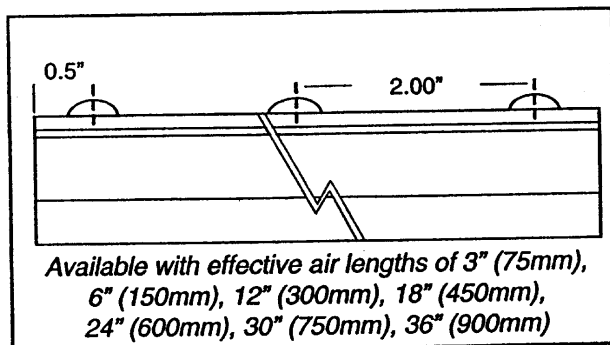

Aluminum Air Curtain

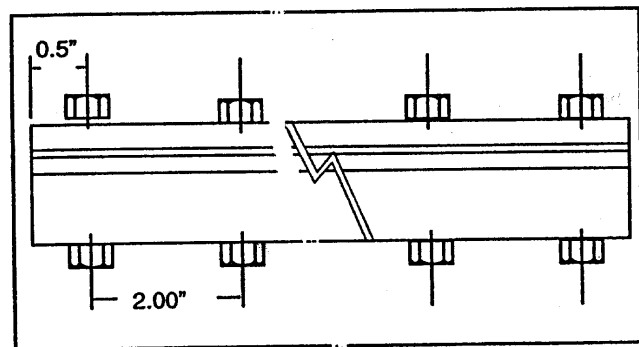

Stainless Steel Air Curtain

Part Number Series 80000 Air Curtains

- 1st digit 8 represents Air Curtain Series
- 2nd digit 5 is aluminum
2nd digit 0 is stainless
- 3rd digit 1 with filter
- 3rd digit 2 with filter and regulator
- Last 2 digits is effective length

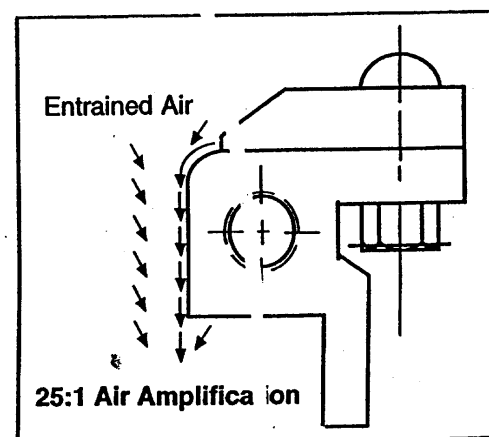

AHP-1200CXP

European

Air Cooled

Thru Mount

Group II, Category 2 [1] G

EExd p d [ia] ia IIB+H2 T4

Thermoelectric Air Conditioner

FEATURES

- Compact, (only 15" L X 7.35" W X 18.4" D)
- Weighs only 39 lbs. (17.7kg)
- Excels in high ambient temperatures
- Environmentally safe
- Vortex Air Amplifier included
- Virtually maintenance-free operation
- Stainless steel exterior housing
- Mounts and operates in any orientation

REQUIREMENTS

- Clean and dry compressed air supply
- Purged enclosure
- 120 VAC Input voltage

INCLUDES

- Mounting gasket and hardware
- Power input line cord
- Temperature control



PERFORMANCE CURVE

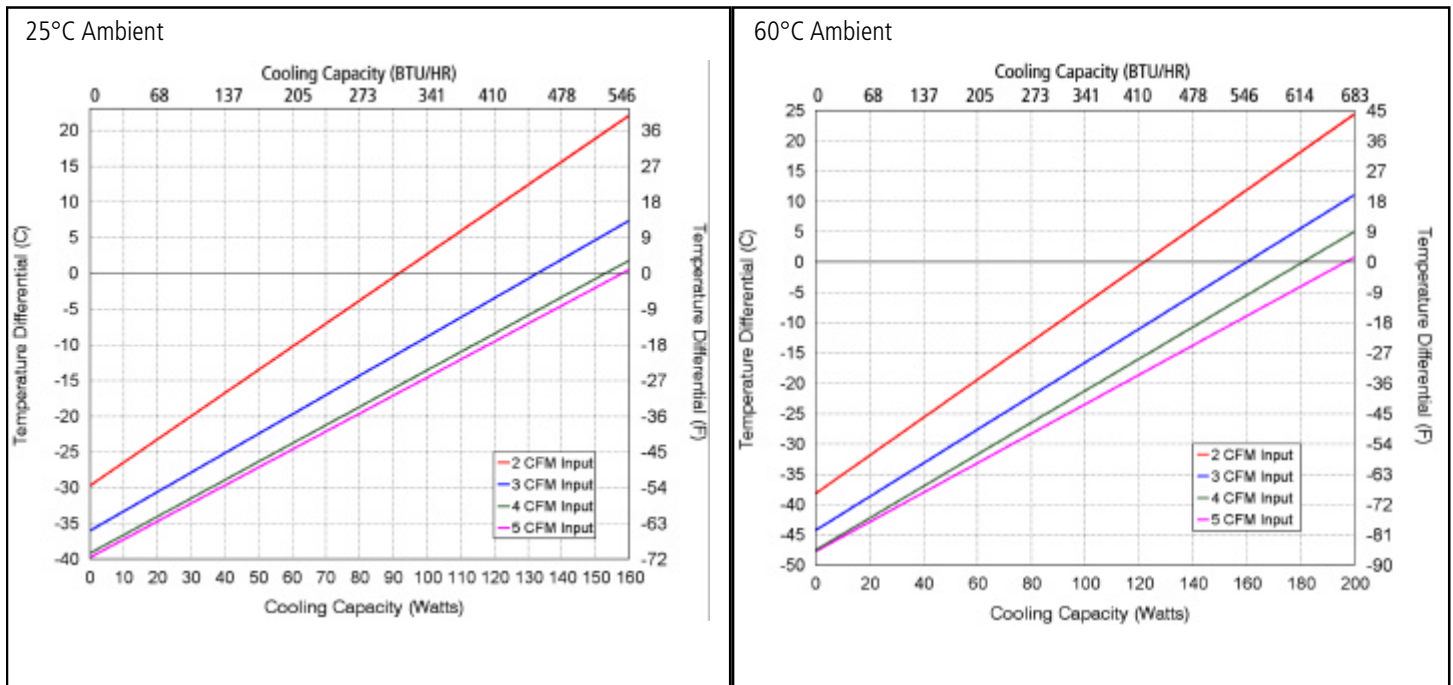

AHP-1200CXP

Thru Mount
Group II, Category 2 [1] G
EEx p d [ia] ia IIB+H2 T4
307-680 BTU/hr

LISTING & CLASSIFICATION:

The AHP-1200CXP is TECA's first solid state air conditioner designed for use in hazardous environments in the United Kingdom and European Union. The AHP-1200CXP features a unique air moving device that eliminates static discharge that traditional fans can generate. A compressed air line is required for the air moving device. The AHP-1200CXP has been successfully implemented with a purged enclosure and other approved equipment in pharmaceutical, petrochemical and other similar applications.

Directive 94/9/EC with reference to EN50014:1997/A2:1999, EN50016:2002.

Procedure XF011, XF013

Group II, Category 2 [1] G EEx p d [ia] ia IIB+H2 T4 Ta=-20 °C to +40 °C

SPECIFICATIONS

MODEL	PART NUMBER	NOTES	PERFORMANCE RATING (BTU/HR)	VOLTAGE (VAC 50/60 HZ)	CURRENT AMPS.	WEIGHT LBS.(KG)	TEMP. CONTROL	OPERATING AMBIENT (°C)
AHP-1200CXP	0-3070-2-018	Cool Only	307-680	120	4.0	39(17.7)	OPT*	-20/+40

* Requires 3-32 VDC drive signal

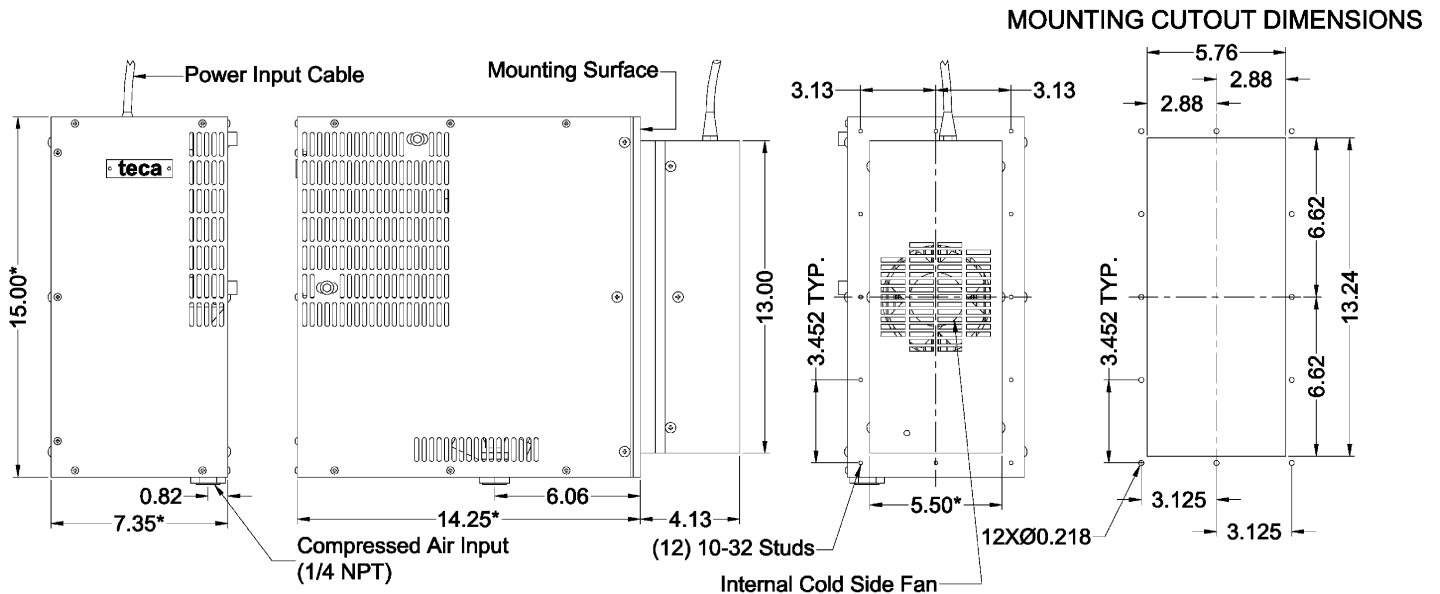
DIMENSIONS

* Dimension does not include hardware. Dimensions: Inches
Mounting hardware and gasket included but not shown.

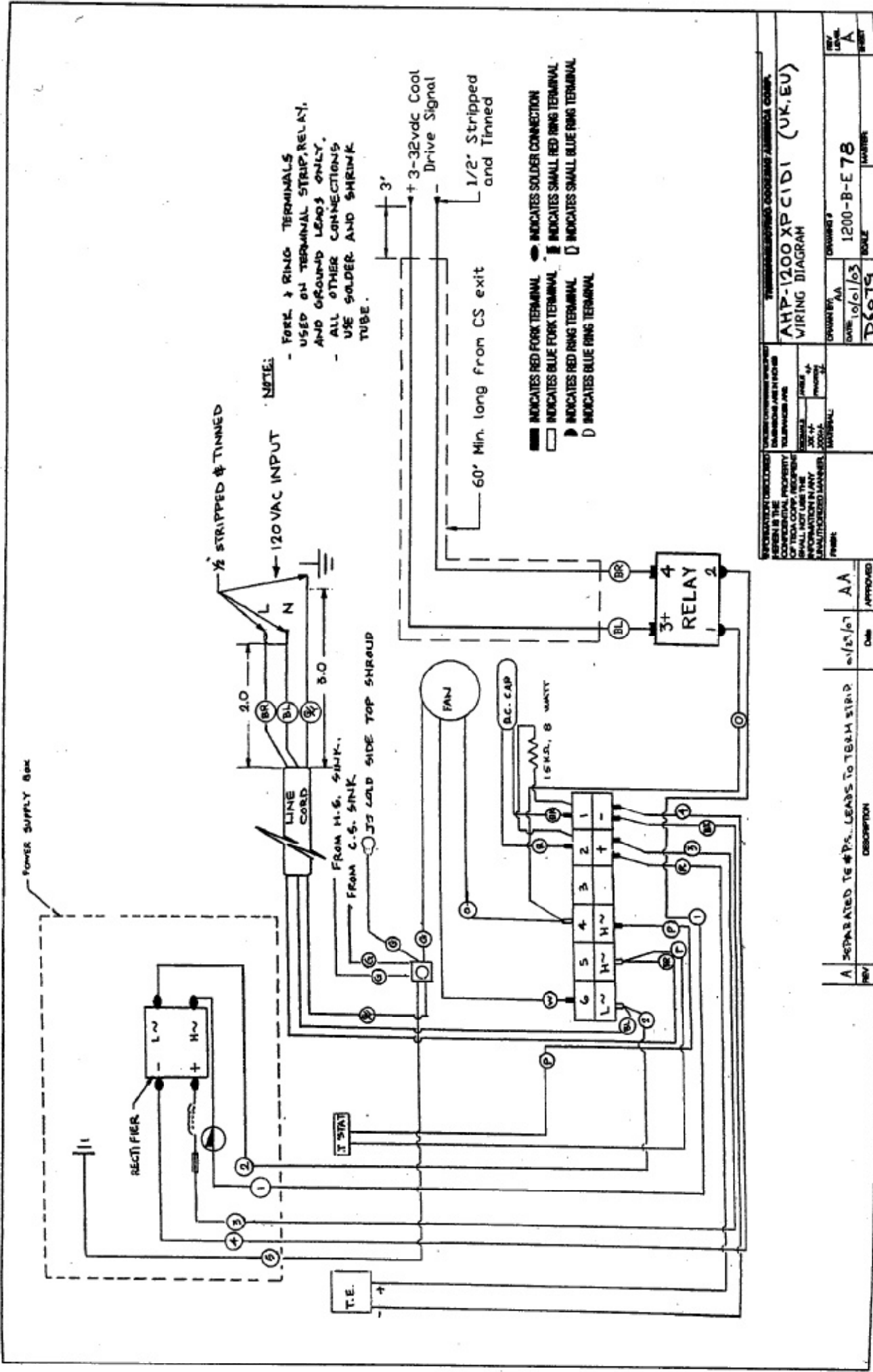

NOTE:

- FORK & RING TERMINALS USED ON TERMINAL STRIP, RELAY, AND GROUND LEADS ONLY.
- ALL OTHER CONNECTIONS USE SOLDER AND SHRINK TUBE.

■ INDICATES RED FORK TERMINAL ● INDICATES SOLDER CONNECTION
 □ INDICATES BLUE FORK TERMINAL ■ INDICATES SMALL RED RING TERMINAL
 ▽ INDICATES RED RING TERMINAL ◻ INDICATES SMALL BLUE RING TERMINAL
 ◊ INDICATES BLUE RING TERMINAL

THIS DOCUMENT IS UNCLASSIFIED
 EXCEPT WHERE SHOWN OTHERWISE
 IN THE CONFIDENTIALITY STATEMENTS
 WHICH ACCOMPANY THIS DOCUMENT
 AND WHICH ARE CONTROLLED BY THE
 INFORMATION SECURITY POLICY
 OF THE NATIONAL SECURITY AGENCY
 DATE 10/01/03 BY 60324
 AUTHORITY 1200-B-E-78

REV	DESCRIPTION	DATE	APPROVED
A	SEPARATED TO TR. LEADS TO TERM STRIP	01/01/07	AA
REV	DESCRIPTION	DATE	APPROVED
A	1200-B-E-78	10/01/03	AA

AHP-1200 XPCIDI (UK.EU)
 WIRING DIAGRAM
 DRAWN BY: AA
 DATE: 10/01/03
 SCALE: 1:1
 NUMBER: 1200-B-E-78

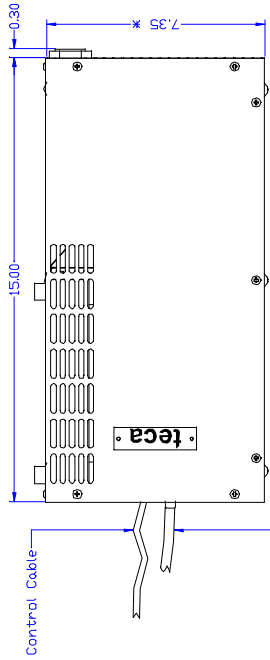
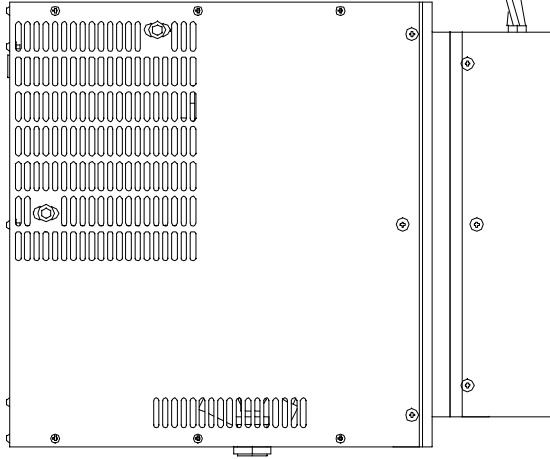
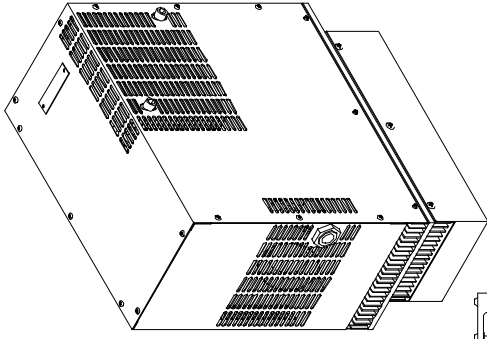

Compressed Air Input
(3/8) NPT

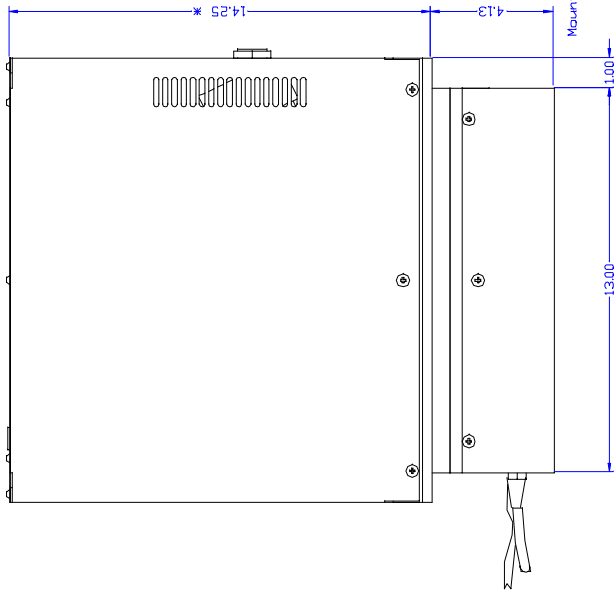
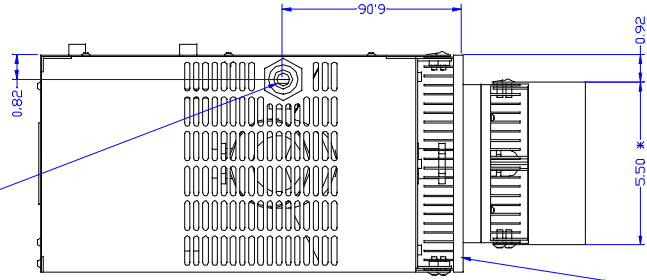

* Dimension does not include hardware.
Mounting hardware and gasket not shown.

INFORMATION DISCLOSED THIS DRAWING IS THE PROPERTY OF TECA CORP. RECIPIENT SHALL NOT USE THE INFORMATION IN ANY UNAUTHORIZED MANNER.	FINISH:	MATERIAL:	DRAWN BY: AA	DRAWING #: 1200-B-A232	REV. LEVEL:
	DATE: 09/16/03	SCALE:	MAP: 9/18	SHEET:	1200-B-1060
UTILISE DIMENSIONS SPECIFIED UNLESS OTHERWISE NOTED DIMENSIONS ARE:	DECIMALS: .XX +/-	FRACTION: XXXX/16	THERMOELECTRIC COOLING AMERICA CORP. AHP-1200XP C1D1 (UK, EU) ASSEMBLY		

REV	DESCRIPTION	DATE	APPROVED

MOUNTING CUTOUT DIMENSIONS

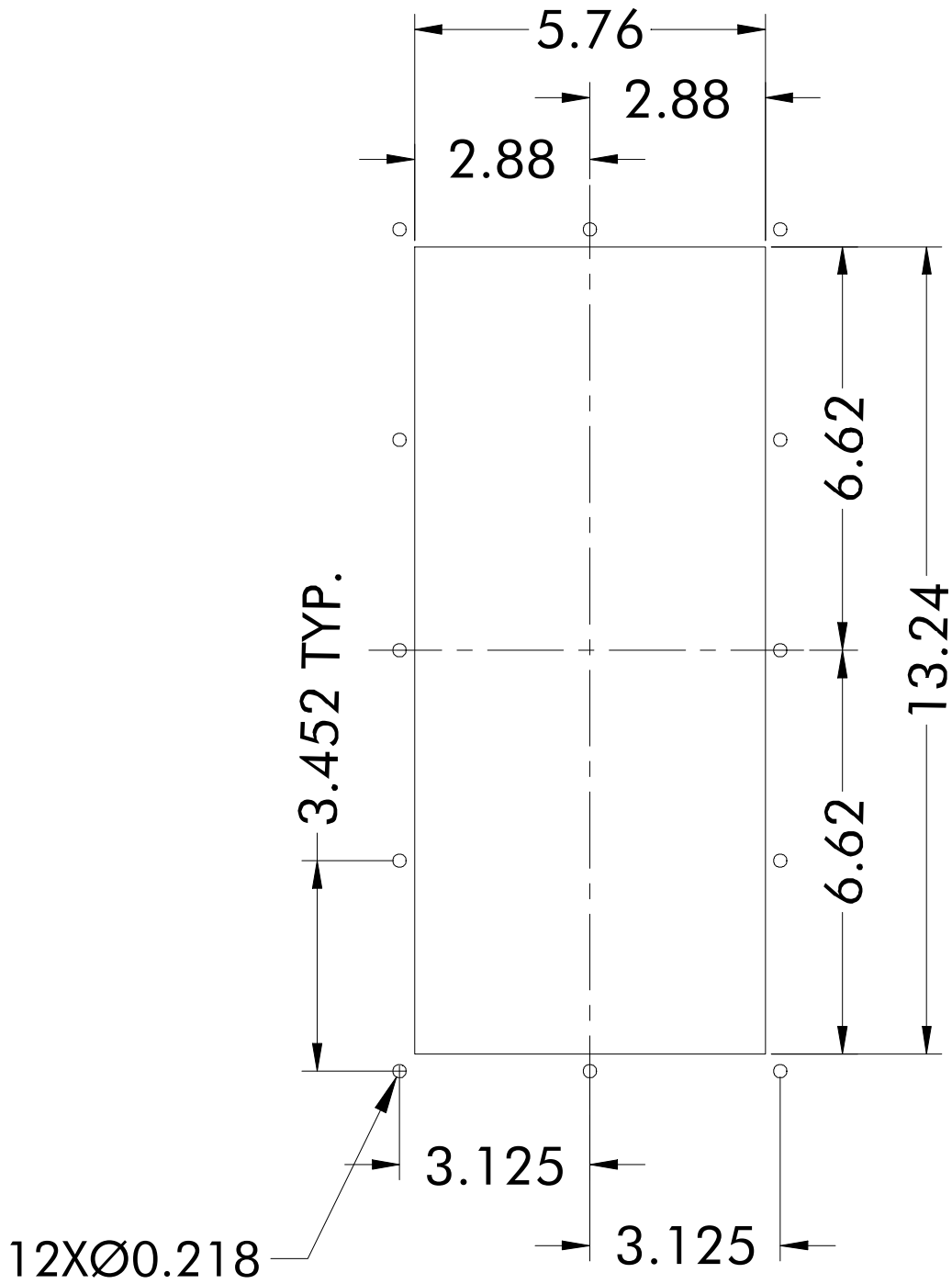

LIMITED WARRANTY

In the event a defect in material or workmanship is discovered in any of TECA's products within one year after the date they are delivered to Buyer, and if: (a) TECA is notified of the defect in writing by certified mail within 14 days of the date of discovery; (b) TECA may then either, at its sole discretion, inspect the product at Buyer's location, or require that the product be made available at Buyer's expense at TECA's premises for TECA's inspection within 14 days of the date of notification; and (c) the products are defective and the defects result from faulty materials and/or workmanship and not in any way from accident, misuse, misapplication, mishandling, modification, or alteration by the Buyer or the shipper, then TECA shall, at its sole option, repair or exchange defective products free of charge to Buyer, or credit to buyer the price of the defective products. ALL OTHER WARRANTIES, EXPRESS OR IMPLIED, ARE EXCLUDED, INCLUDING BUT NOT LIMITED TO THE IMPLIED WARRANTIES OF MERCHANTABILITY AND FITNESS FOR A PARTICULAR PURPOSE. IN NO EVENT SHALL TECA BE LIABLE FOR ANY CLAIM BASED UPON BREACH OF EXPRESS OR IMPLIED WARRANTY OR ANY OTHER DAMAGES WHETHER SPECIAL, INDIRECT, INCIDENTAL, CONSEQUENTIAL, LOST PROFITS, BUSINESS INTERRUPTION, OR LOSS OF BUSINESS OR CUSTOMER RELATIONSHIPS.

RETURNED GOODS, RESTOCKING CHARGES

In order to return merchandise for any reason (repair, replacement, or credit) a return authorization number must be issued by TECA. New merchandise may not be returned for credit beyond 60 days from shipment. Charges for incidental or other damages may also be made. All returned goods must be sent freight prepaid. A restocking charge of 15% will apply. On special equipment and custom modified equipment orders, additional incremental cancellation charges may be made.