

Product Information Packet

Model AHP-3259XEHC

Solid State, NEMA 4, Heat/Cool, Air Conditioner

with TC-5300D Temperature Control

Part #0-I5LB-5-000

Thank you for your purchase. Information has been enclosed regarding the installation, specifications, and wiring of your solid-state assembly. Please read and follow all instructions carefully before installation. Only qualified technicians should install this equipment.

If you have any questions regarding your equipment, please do not hesitate to call us at 773-342-4900, and we will be happy to assist you. We are open from 8:00 am-4:30 pm Central Time.

Included in this packet you will find:

Installation Notes for Air Conditioners

Product Literature and Specifications

Wiring Drawing # SK170555

Installation Drawing # SK121014

Temperature Control Information

Warranty Information

The logo for Teca, featuring the word "teca" in a bold, lowercase, sans-serif font. The letter "t" is stylized with a vertical line extending upwards from its stem.

ThermoElectric Cooling America Corporation
4048 W. Schubert Avenue • Chicago, IL (U.S.A.) 60639
Ph: 773/342-4900 Fx: 773/342-0191
sales@thermoelectric.com www.thermoelectric.com

Important Installation Notes for Air Conditioners

Mounting Styles: Both 'thru mount' and 'flush mount' units can be positioned in any orientation and on any enclosure surface. It is important to consider interior air flow patterns when determining the mounting location. Also of importance is an unrestricted flow of ambient air thru the hot side heat exchanger. Ease of access and inspection must be considered for those applications in particularly severe environments which may require occasional maintenance.

Vertical (Side/Front/Back) Mounting:

Vertical mounting refers to the vertical direction of the cold side or interior fins and is recommended for applications with high humidity, poor and incomplete cabinet seals or any condition which may cause the cold side fins to be maintained at temperatures below the dew point for long periods of time allowing for the formation of condensation. The vertical fin direction provides a drip path whereupon condensation can be collected via a moisture removal system (standard on FHP-units) or a drip pan positioned below the cold side fins. Drip pans are optional for thru mount units.

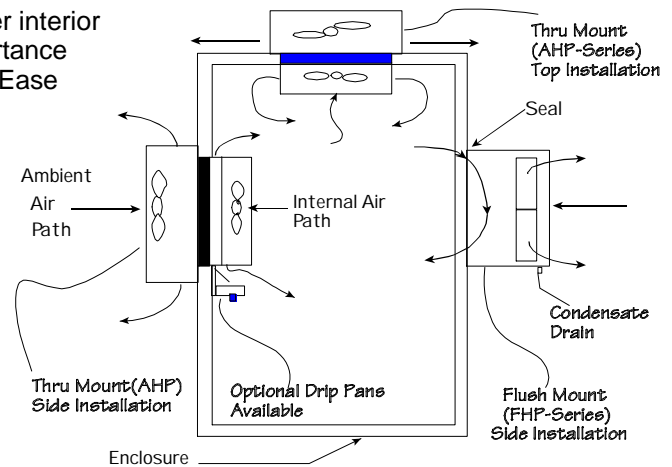

Condensate Removal System:

All FHP-Series and AHP-1400 air conditioners contain a built-in condensate removal system. The condensate kit consists of an antifungal sponge with a condensate wick. PVC tubing is also provided for drainage. Drip pans are optional for thru mount units which must be evaluated on an individual basis. Equations defining a relationship between the cold side fin and enclosure temperatures are provided to assist in the evaluation.

Top Mounting:

Though often the easiest location to mount it is often the most difficult to protect from condensation in this orientation due to the fin orientation, gravity and any susceptible components below. If a drip pan is employed by the end user use caution to place the pan far enough away from the internal fan to minimize the restriction of air flow. The pan should cover the fin ends as well as the fan area. When there is a choice, the vertical orientation is preferred by most users.

Maintenance:

Since the technology is solid-state, there are no filters, compressors, or fluorocarbons to maintain. The only moving parts are the fans. It is recommended for harsh or dirty environments that the heat sinks be cleaned from time to time. This can be accomplished by directing compressed air over the external fins or on NEMA 4 versions by hosing the unit down. This will increase the overall life and performance of the system.

Cautions:

Take care when mounting not to damage the seal between the hot and cold side sinks. Do not attempt to mount a unit to a warped surface or try to make the units mounting surface conform to an unflat surface. Do not pinch or damage any leads when mounting. Do not over tighten any installation screw, use reasonable force. Always mount with any condensate drain down. Do not compress the cold side between the hot side and any other surface. Do not obstruct the airflow on either side. When mounting consider the natural air flows of the enclosure. Connect power only after the installation is complete.

Notes on condensation:

Condensation occurs at the cold side fins when the surface temperature goes below the dew point. To reduce or remove condensate, consider the following:

- Regulate the Fin Temperature above the Dewpoint.
- Keep Enclosure Closed and Sealed from Outside Humidity.
- Use Desiccant (Moisture absorbing Granules.)
- Employ Condensate Removal System/Drip Pans.

If you have any questions regarding your installation, Please feel free to contact our technical department for assistance at 773-342-4900.

AHP-3259

Air Conditioner/Heat Exchanger

Air Cooled
Through Mounted
Nema-12, 4

100-240 VAC Input
High Capacity
2400 BTU/HR

FEATURES

- High capacity thermoelectric design
- Power saving air to air heat exchanger mode (ECO-Mode)
- Heavy duty full perimeter mounting
- Lower profile intrusion into enclosure
- Central input cord for easy mounting
- Closed loop design
- Condensate control and evaporation system
- Compact
- Increased efficiency at higher ambient by as much as 10%
- Virtually maintenance free
- No compressor
- Environmentally friendly and safe
- Stainless Steel exterior housing
- Mounts and operates in any orientation
- Integral temperature controller
- Weight 82 LBS.



CONTROL TEMPERATURES

Active Cooling	35 °C
Heat Exchanger (ECO-Mode)	25 °C
Active Heating	10 °C
Typical Hysteresis	5 °C
Operating Ambient	-40/+65 °C
Operating Enclosure	-10/+60 °C

POWER INPUTS

Input Voltage	100 - 240 VAC
Current, Active	11 - 4.6 AMPS
Alternate Input Voltage	127 - 374 VDC
Current , ECO-Mode (@120 vac)	1.5 AMP
Frequency	47 - 63 / 440 Hz
Power Consumption	1100 Watts

PERFORMANCE RATINGS

Cooling (Traditional)	2400 BTU/HR
Cooling (Din 3168)	705 WATTS
Cooling COP (at L35 L35)	0.64
Heating (Traditional)	> 1200 BTU/HR
Heating (Din 3168)	> 352 WATTS
Heating COP	> 1.0
Heat Exchanger (ECO-Mode)	12.5 W/°C

INCLUDES

- Power supply
- Temperature controller
- Power saving heat exchanger mode (ECO-Mode)
- Mounting gasket
- Mounting hardware
- Power input cord

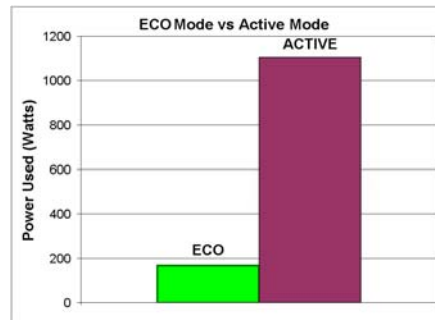

200 - 277 VAC (254 - 420 VDC) Versions available

CONFIGURATIONS

MODEL	PART NUMBER	NOTES	TEMPERATURE CONTROL	ENVIRONMENT
AHP-3259	0-I5JB-0-000	Cool only, industrial fans	TC-4F	NEMA-12, IP 52
AHP-3259	0-I55B-0-000	Cool only, industrial fans	EXT*	NEMA-12, IP 52
AHP-3259HC	0-I5IB-1-000	Heat/Cool, industrial fans	TC-7F	NEMA-12, IP 52
AHP-3259HC	0-I55B-1-000	Heat/Cool, industrial fans	EXT*	NEMA-12, IP 52
AHP-3259XE	0-I5JB-4-000	Cool only, sealed hot side fans	TC-4F	NEMA-4, IP 56
AHP-3259XE	0-I55B-4-000	Cool only, sealed hot side fans	EXT*	NEMA-4, IP 56
AHP-3259XEHC	0-I5IB-5-000	Heat/Cool, sealed hot side fans	TC-7F	NEMA-4, IP 56
AHP-3259XEHC	0-I55B-5-000	Heat/Cool, sealed hot side fans	EXT*	NEMA-4, IP 56
AHP-3259XEHC†	0-I5LB-5-000	Heat/Cool, sealed hot side fans	TC-5300D	NEMA-4, IP56

† Precise temperature control model

* Unit is set for 5-32 VDC external signal, relay(s) included

AHP-3259

MOUNTING STYLE

Through Mounted

ENVIRONMENTS SERVED

NEMA-12 IP 52

NEMA-4 IP 56

RATING (TRADITIONAL)

2400 BTU/hr @ 0 °F ΔT

RATING (DIN 3168)

705 Watts L35 L35

330 Watts L35 L50

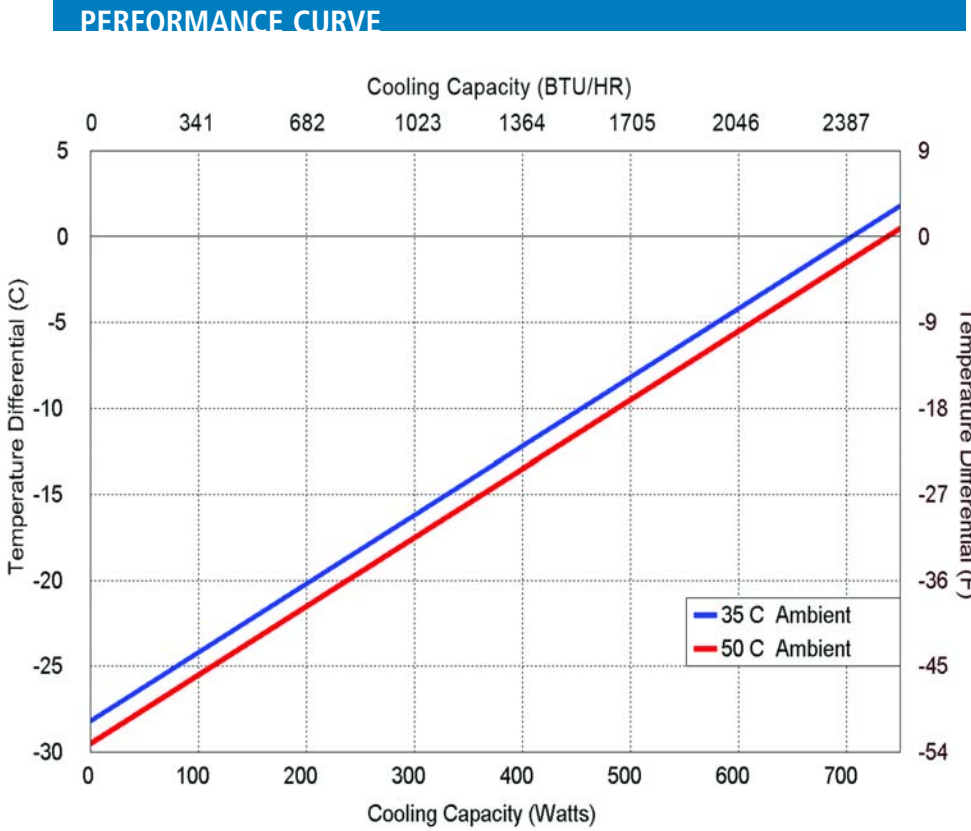

Equation of line: $y = \Delta T(^{\circ}C)$ $x = \text{Capacity (Watts)}$		
Ambient Temp	35°C	50°C
Enclosure Air	$y = .04x - 28.2$	$y = .04x - 29.5$
Cold Sink	$y = .029x - 28.2$	$y = .029x - 29.5$

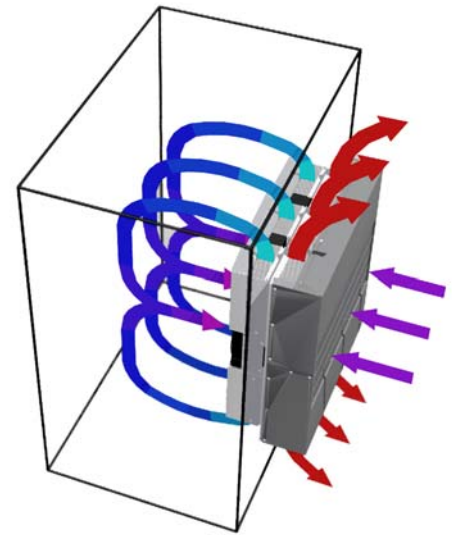

Air Flow Pattern

DIMENSIONS

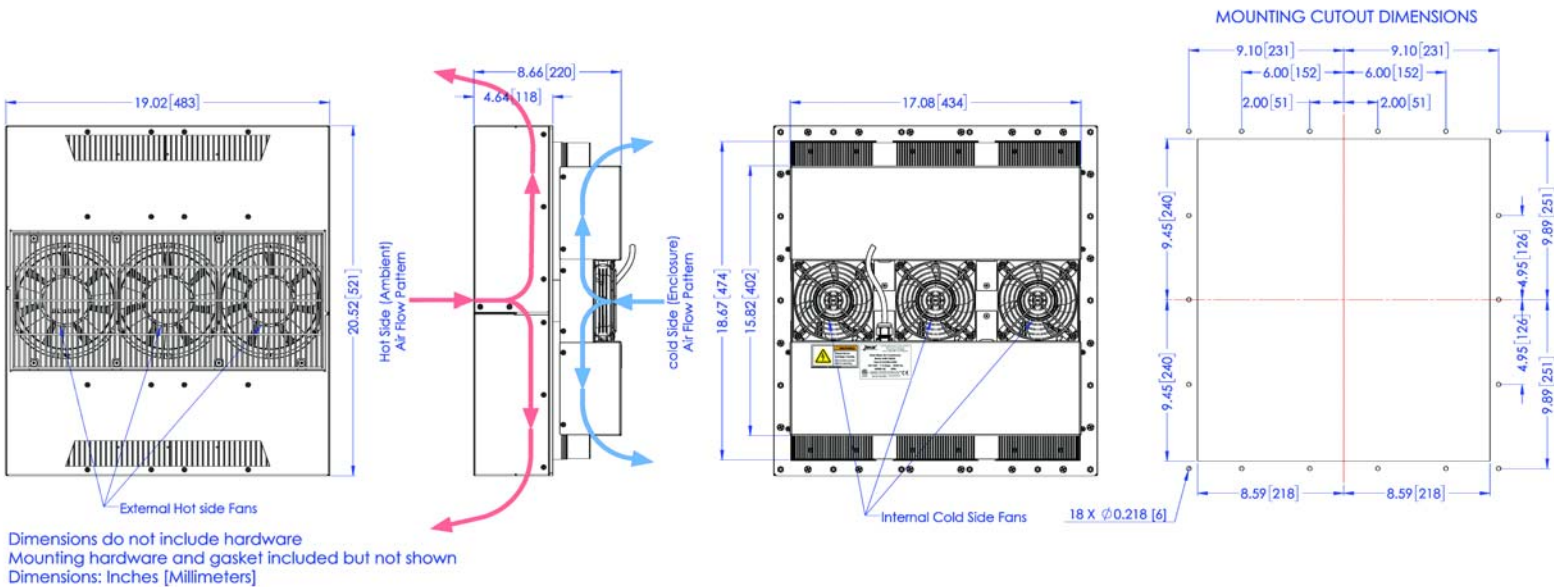

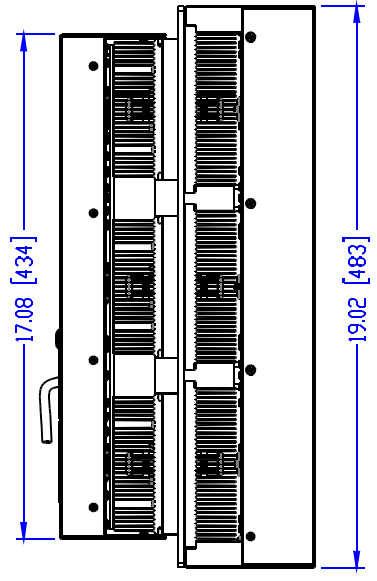
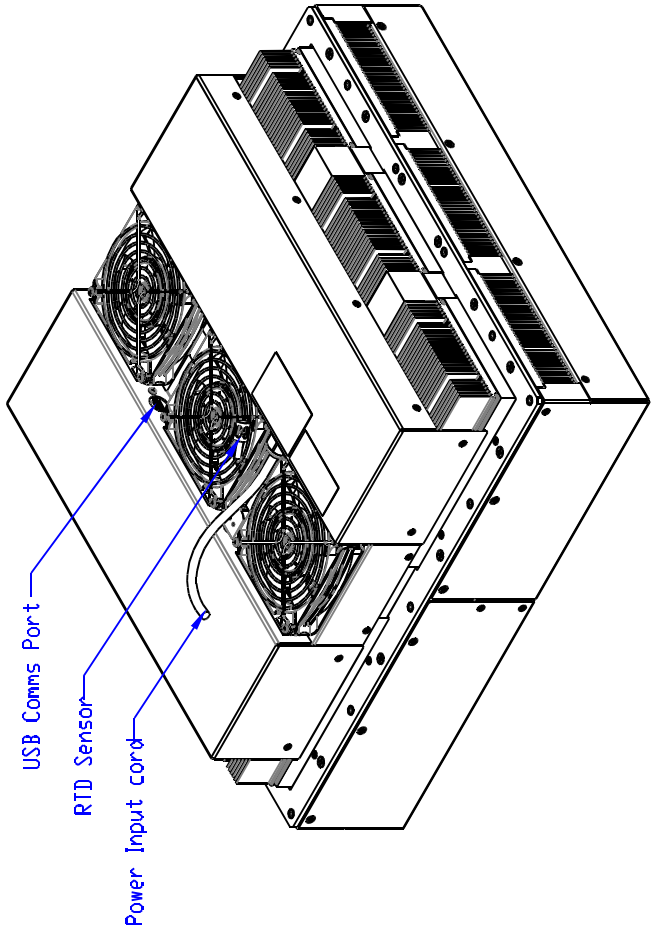
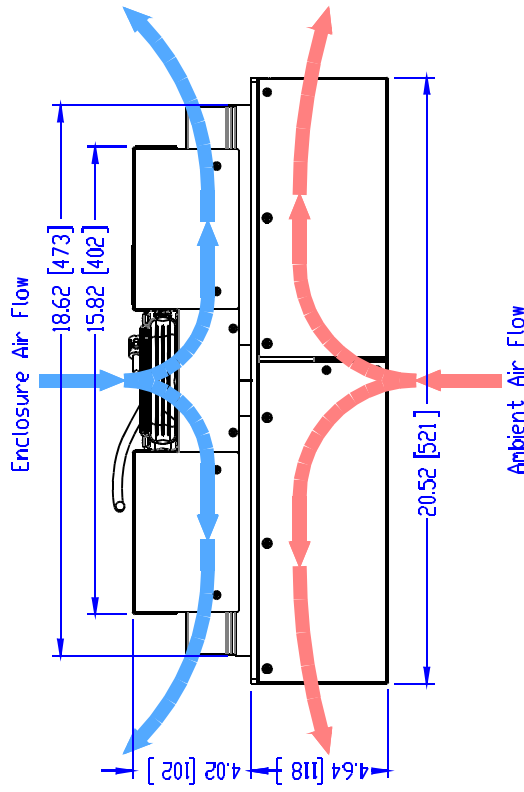
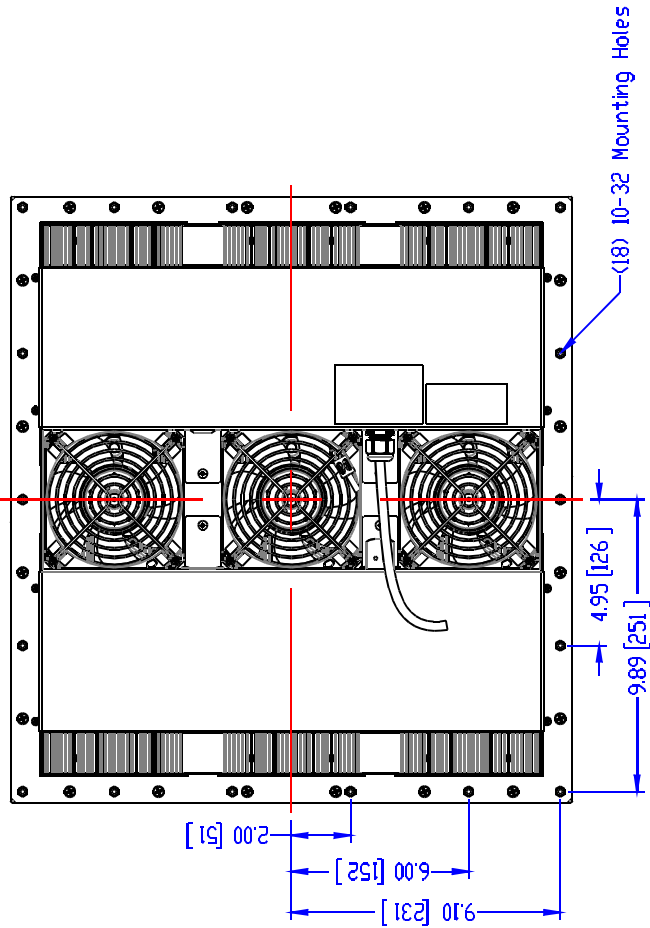

UNLESS OTHERWISE SPECIFIED:		NAME	DATE
DIMENSIONS ARE IN INCHES		AA	08/23/17
TOLERANCES:			
FRACTIONAL ±			
ANGULAR: MACH ±	BEND ±		
TWO PLACE DECIMAL ±			
THREE PLACE DECIMAL ±			
INTERPRET GEOMETRIC TOLERANCING PER:		PROPRIETARY AND CONFIDENTIAL THE INFORMATION CONTAINED IN THIS DRAWING IS THE SOLE PROPERTY OF TECA CORPORATION. ANY REPRODUCTION IN PART OR AS A WHOLE WITHOUT THE WRITTEN PERMISSION OF TECA CORPORATION IS PROHIBITED.	
MATERIAL			
FINISH			
DO NOT SCALE DRAWING			
		SIZE	REV
		A	SK170852
		S1177	SHEET 1 OF 1
		AHP-3259 SERIES WITH TC-5300D ASSEMBLY	

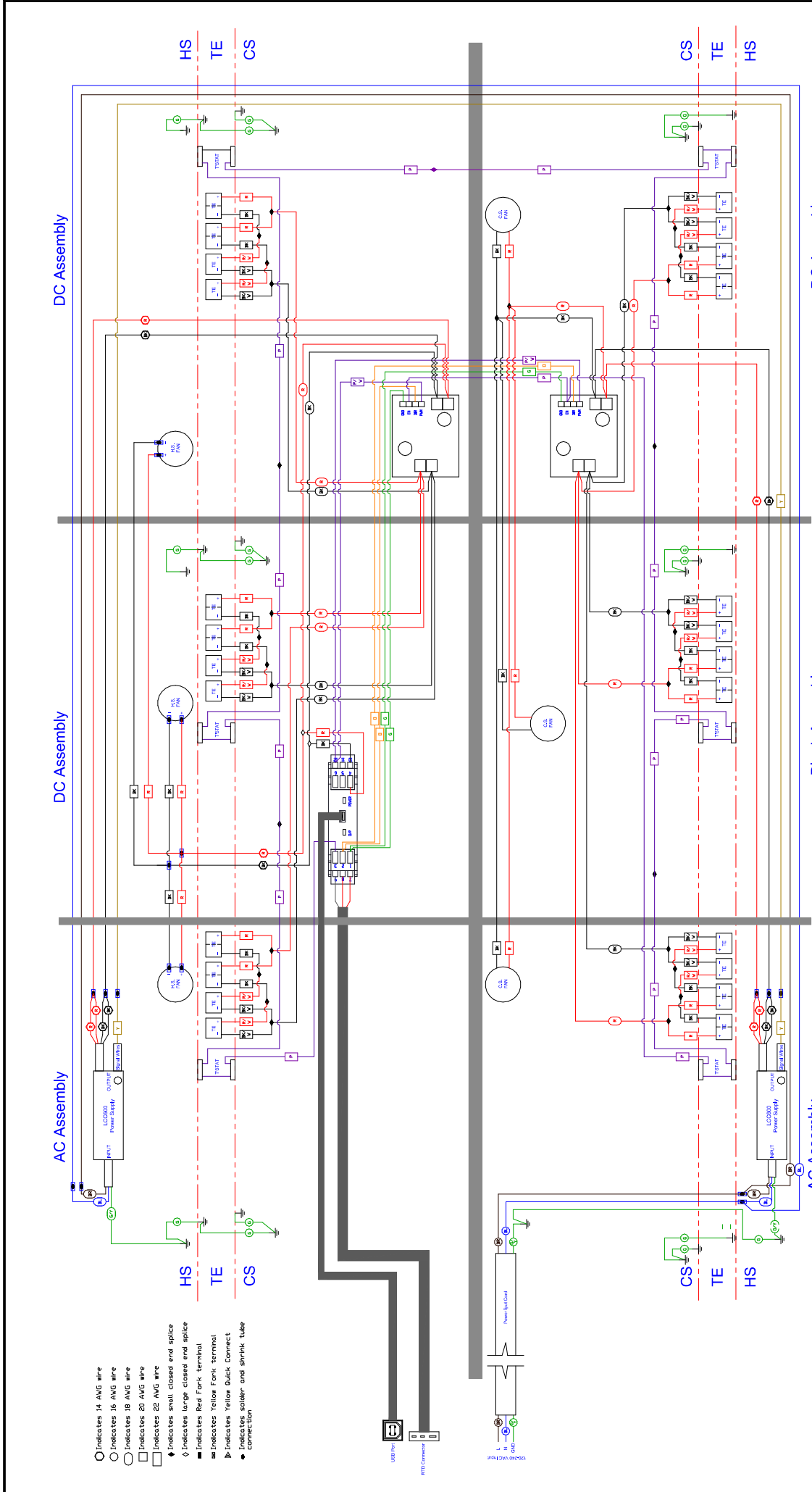

DC Assembly

DC Assembly

AC Assembly

DC Assembly

Blank Assembly

AC Assembly

- Indicates 14 AWG wire
- Indicates 16 AWG wire
- Indicates 18 AWG wire
- Indicates 20 AWG wire
- Indicates 22 AWG wire
- ◆ Indicates small closed end splice
- ◆ Indicates large closed end splice
- ◆ Indicates Red Fork terminal
- ◆ Indicates Yellow Fork terminal
- ◆ Indicates Yellow Quick Connect
- ◆ Indicates solder and shrink tube connection

INFORMATION DISCLOSED HEREIN IS THE CONFIDENTIAL PROPERTY OF TECA CORP. RECIPIENT SHALL NOT USE THE INFORMATION IN ANY UNAUTHORIZED MANNER. FINISH:		UNLESS OTHERWISE SPECIFIED DIMENSIONS ARE IN INCHES. TOLERANCES ARE:	THERMoeLECTRIC COOLING AMERICA CORP. AHP-3259XEHC WITH TC-5300D WIRING DIAGRAM
DECIMALS	ANGLE	FRACTION	DRAWN BY: PAA
.XX +/-	1/16	1/16	DATE: 06/01/2017
.XXX +/-			DRAWING # SK170555
			SCALE S1023
			REV LEVEL
			MASTER
			SHEET

REV	DESCRIPTION	Date	APPROVED

Mounting, Monture, Montage, Montaggio

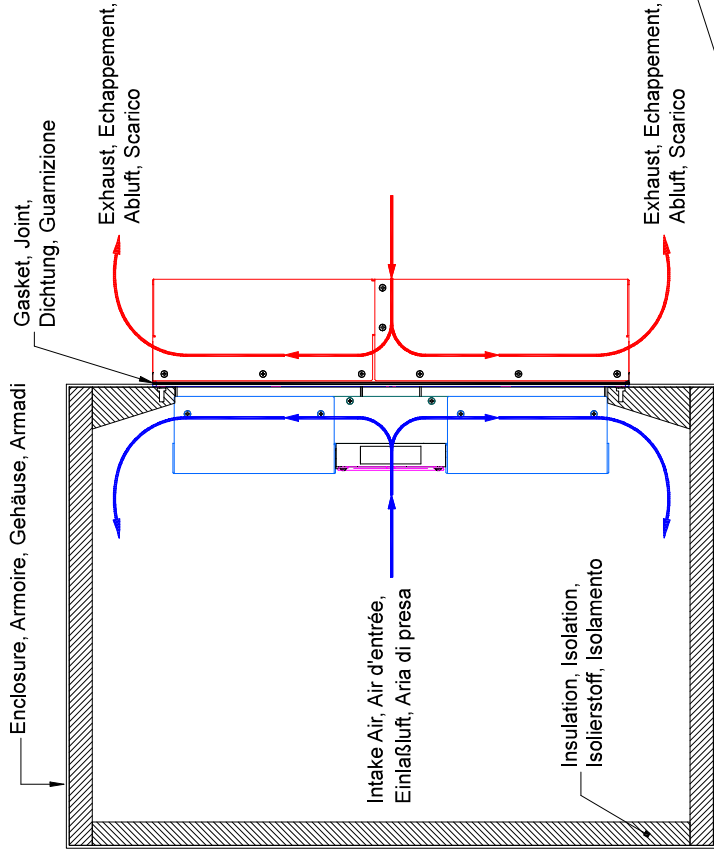

MOUNTING CUTOUT DIMENSIONS

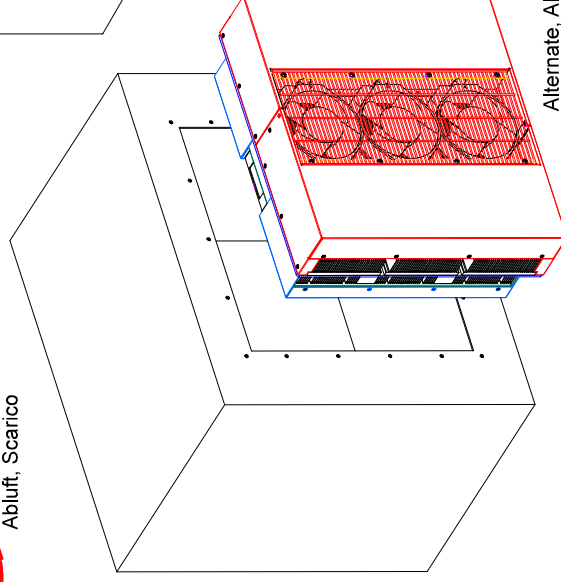
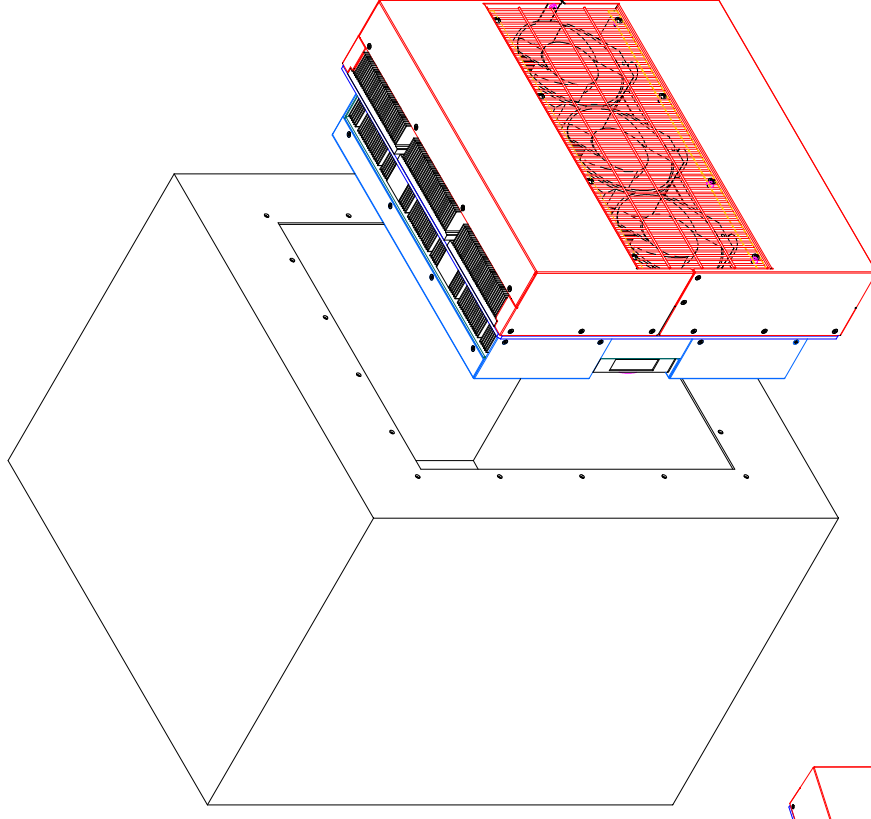
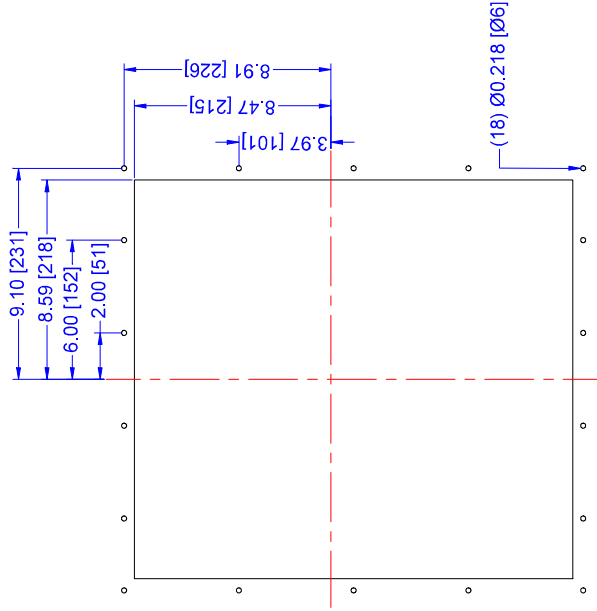

Alternate, Alternative,
Alternative, Alternativa

English, Français, Deutsch, Italiano
Dimensions: Inches [Millimeters]

INFORMATION DISCLOSED HEREIN IS THE CONFIDENTIAL PROPERTY OF TECA CORP. RECIPIENT SHALL NOT USE THE INFORMATION IN ANY UNAUTHORIZED MANNER.	UNLESS OTHERWISE SPECIFIED DIMENSIONS ARE IN INCHES TOLERANCES ARE:	DRAWN BY: AA		DRAWING # SK121014	REV LEVEL
		DATE: 07/19/2012	SCALE		
FINISH: 10/19/2012		D8572		THERMOELECTRIC COOLING AMERICA CORP.	
AHP-3200 SERIES TYPICAL FIELD MOUNTING		MATERIAL:		REV LEVEL	
DECIMALS .XX +/-		ANGLE +/-		SHEET	
FRACTION .XXX +/-		FRACTION +/-		SHEET	

TC-5300 PWM Temperature Controller

PWM Temperature Control

Pulse Width Modulating Temperature Controller

OVERVIEW

The **TC-5300** PWM temperature controller is an innovative new thermal control platform for precision temperature control applications. Designed specifically for thermoelectric temperature control, the TC-5300 controller incorporates features like PWM, bi-directional power, 4 temperature-zone auto-tune PID, broad sensor support, and a USB interface with software for managing the controller using a computer.

The TC-5300 controller is available in panel and din rail mount versions.

FEATURES

Control Modes: Up to Four Temperature Zones P, PI, PD, PID, Autotune Open-loop Control

Output: PWM 1KHz, duty cycle resolution=1000 steps Hot / Cold direction (logic 0/1)

Input: Thermocouple: J, K, T; RTD: PT100 (DIN); Thermistor: 2252 ohm or 10K ohm

Resolution: 0.1°C

Communications: USB, interface cable included

H-Bridge: Use with one or multiple **HA-5300** 700 watts H-Bridge Amplifier

Software: tecaLOG Windows based real time plotting, logging, programming and tuning software

LabView: Write your own LabView program (VI examples available)

Includes: wiring harness, USB cable and driver, tecaLOG software

Ingress Protection: IP65 front panel (applies to panel mount only)

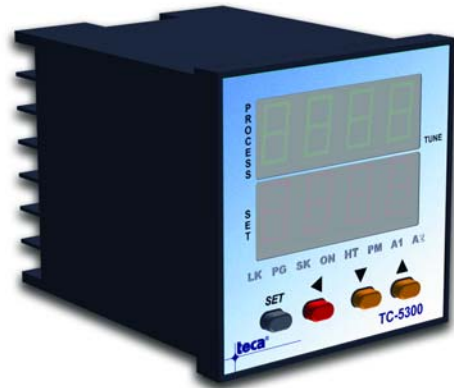

TC-5300 Panel Mount



TC-5300 Din Rail Mount

SPECIFICATIONS

General

Rated Voltage: 9~36 VDC

Power Consumption: Less than 3VA
(100mA@24VDC)

Memory Backup: EEPROM and non-volatile memory
(Approx. 10 years)

Operation Condition Temperature: 0 ~ 50°C,
Humidity 0 ~ 90% RH (Non-condensing)

Input

Thermocouple: J, K, T

RTD: DIN PT-100 (2 or 3 wire)

Thermistor: 2252 ohm, 10k ohm

Range: -50°C ~ 200°C (*sensor type dependable)

Accuracy: ±0.2°C (3 wire RTD)

Cold Junction Compensation: 0.1°C/°C ambient

Normal Mode Rejection: 60 dB

Common Mode Rejection: 120 dB

Control Function

Proportional Band: 0.0 ~ 100.0 %

Integral Time: 0 ~ 3600

Derivative Time: 0 ~ 900

Sampling Rate: 10Hz

Temperature Control Res.: 0.1°C / 0.1°F

Programmable Profile: 8 Steps, ramp/soak time,
loop-in-loop, complex loop profile

Control Software: Full function Windows Program,
plot, chart, log data, sensor select, set temperature,
monitor process

Output

Display Resolution: 0.1°C / 0.1°F or 1°C / 1°F

Alarm Relay Output: Logic 5VDC Level (on:1 /off:0)
0.5 mA Max.

PWM Output: Logic 5VDC Level, Freq: 1K Hz

Enable: Logic 5VDC Level

H/C Control Action: Logic 5VDC Level, Direct or
Reverse (for cooling or heating direction)

Communications: USB (RS-485 or RS-232 available
with special request)

HA-5300 H-Bridge Amplifier

Voltage Rating: 5~36V DC

Maximum Current: 30 Amps

Maximum Power Output: 700W (for loads above
350 watts use forced air or other methods to cool the
base of the H-Bridge)

TC-5300

PART NUMBER AND ORDERING

MODEL NUMBER	DESCRIPTION	VOLTAGE VDC	SWITCHING CURRENT AMPS (MAX.)	COMMUNICATIONS
TC-5300	Panel Mount Controller	9 - 36	N/A	USB
TC-5300D	Din Rail Mount Controller	9 - 36	N/A	USB
HA-5300	H-Bridge Amplifier	5 - 36	30*	N/A

* For loads above 350 watts use forced air or other methods to cool the base.
 Maximum rated power is 700 watts, for larger loads use multiple HA-5300 H-Bridge amplifiers.

PANEL MOUNT DIMENSIONS

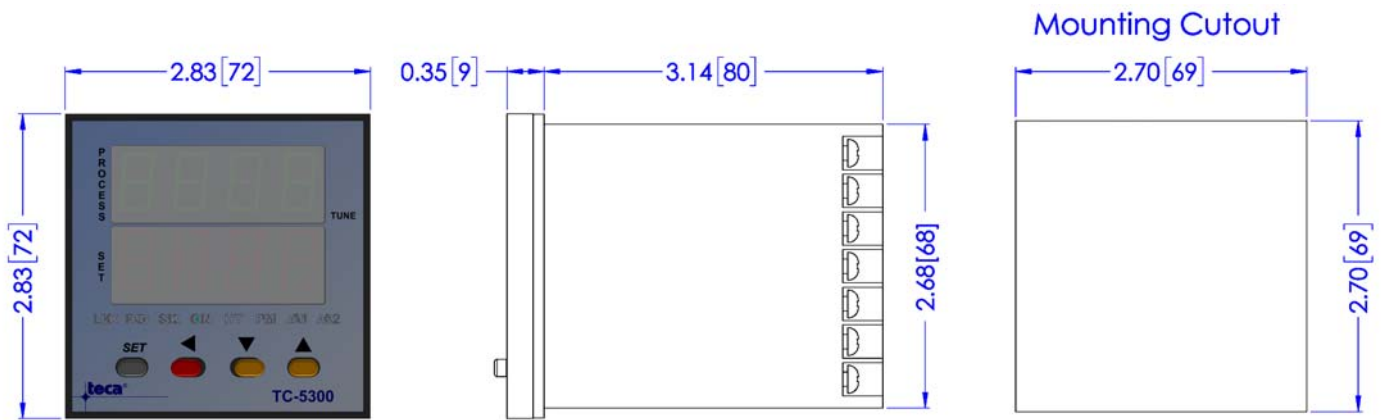

Dimensions: Inches [Millimeters]

HA-5300 DIMENSIONS

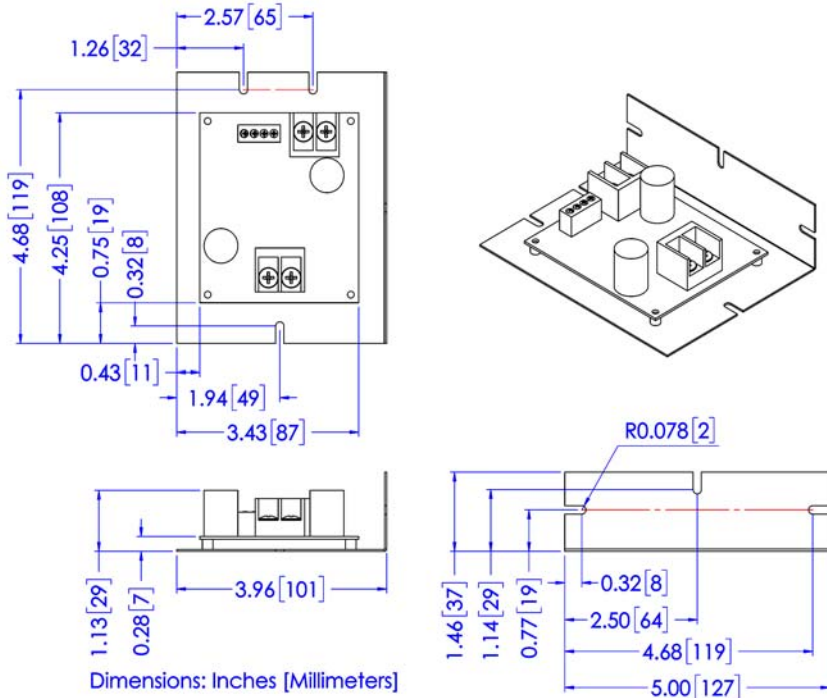

Dimensions: Inches [Millimeters]

DIN RAIL MOUNT DIMENSIONS

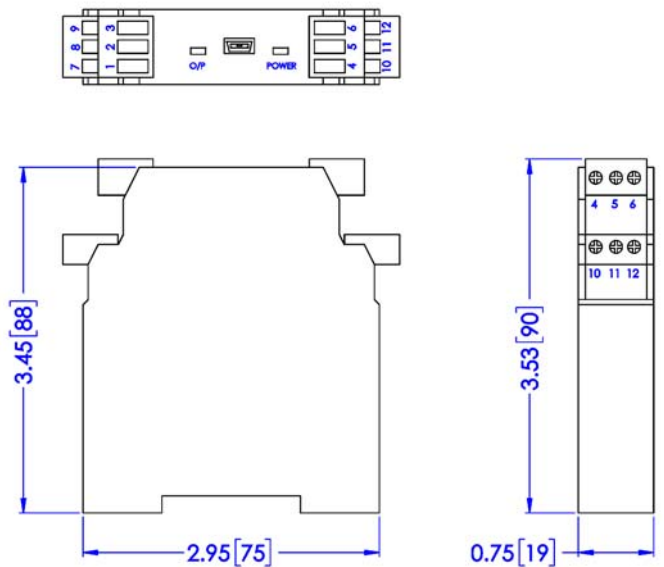

Dimensions: Inches [Millimeters]

LIMITED WARRANTY

In the event a defect in material or workmanship is discovered in any of TECA's products within one year after the date they are delivered to Buyer, and if: (a) TECA is notified of the defect in writing by certified mail within 14 days of the date of discovery; (b) TECA may then either, at its sole discretion, inspect the product at Buyer's location, or require that the product be made available at Buyer's expense at TECA's premises for TECA's inspection within 14 days of the date of notification; and (c) the products are defective and the defects result from faulty materials and/or workmanship and not in any way from accident, misuse, misapplication, mishandling, modification, or alteration by the Buyer or the shipper, then TECA shall, at its sole option, repair or exchange defective products free of charge to Buyer, or credit to buyer the price of the defective products. ALL OTHER WARRANTIES, EXPRESS OR IMPLIED, ARE EXCLUDED, INCLUDING BUT NOT LIMITED TO THE IMPLIED WARRANTIES OF MERCHANTABILITY AND FITNESS FOR A PARTICULAR PURPOSE. IN NO EVENT SHALL TECA BE LIABLE FOR ANY CLAIM BASED UPON BREACH OF EXPRESS OR IMPLIED WARRANTY OR ANY OTHER DAMAGES WHETHER SPECIAL, INDIRECT, INCIDENTAL, CONSEQUENTIAL, LOST PROFITS, BUSINESS INTERRUPTION, OR LOSS OF BUSINESS OR CUSTOMER RELATIONSHIPS.

RETURNED GOODS, RESTOCKING CHARGES

In order to return merchandise for any reason (repair, replacement, or credit) a return authorization number must be issued by TECA. New merchandise may not be returned for credit beyond 60 days from shipment. Charges for incidental or other damages may also be made. All returned goods must be sent freight prepaid. A restocking charge of 15% will apply. On special equipment and custom modified equipment orders, additional incremental cancellation charges may be made.