

⬡ Indicates 10 AWG. wires
 □ Indicates 22 AWG. wires

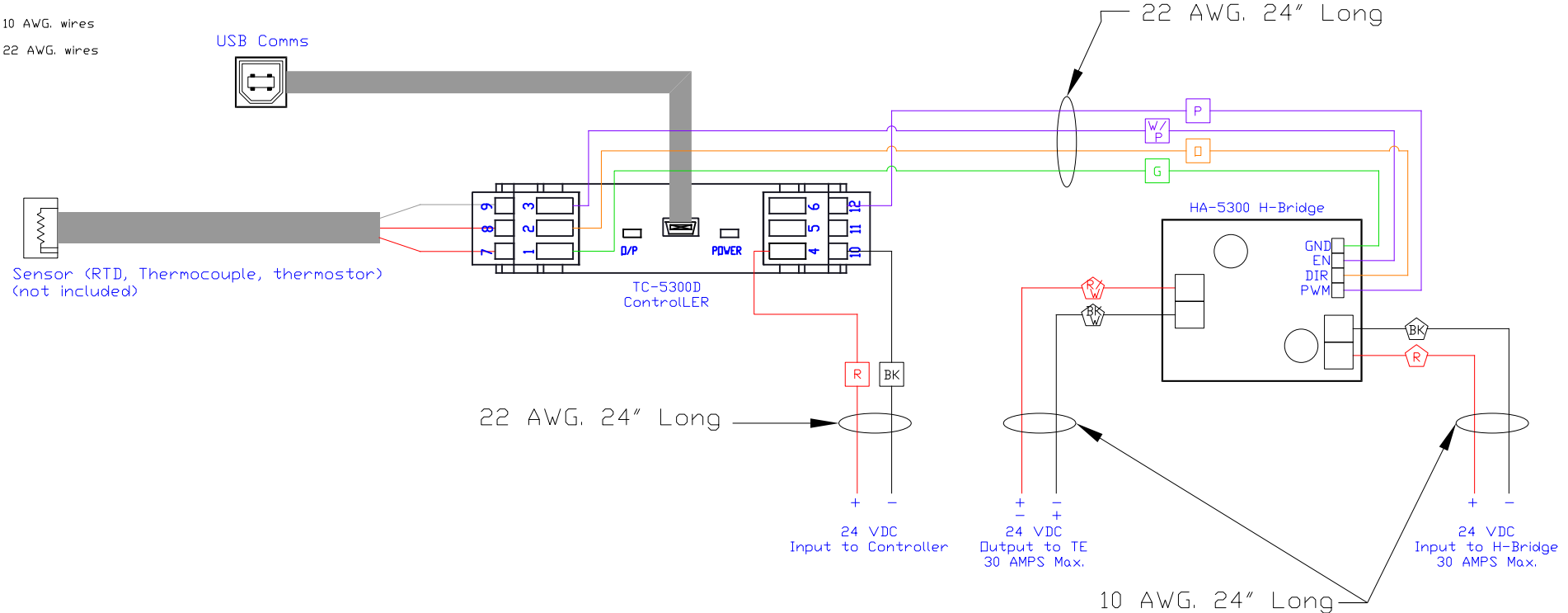

Sensor Type & Dip-Switch Setting

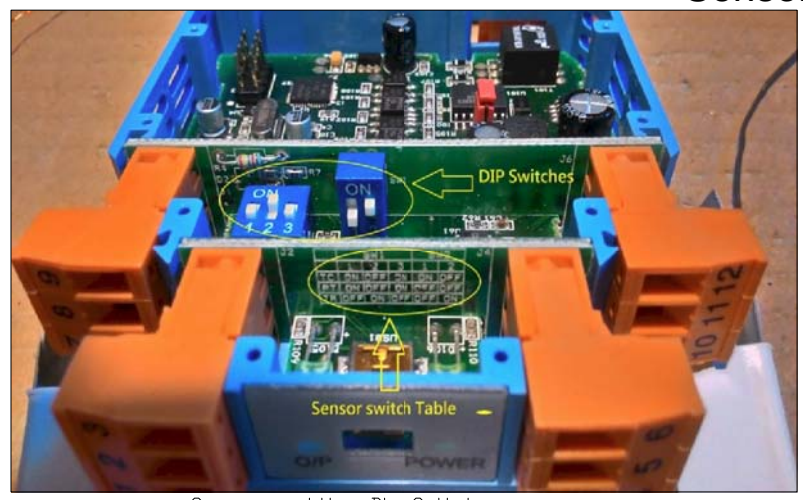

Sensor setting Dip-Switches

	SW1			SW2	
	1	2	3	1	2
TC	ON	OFF	ON	ON	OFF
PT (RTD)	ON	OFF	ON	OFF	OFF
TR	OFF	ON	OFF	OFF	ON

INFORMATION DISCLOSED HEREIN IS THE CONFIDENTIAL PROPERTY OF TECA CORP. RECIPIENT SHALL NOT USE THE INFORMATION IN ANY UNAUTHORIZED MANNER.	UNLESS OTHERWISE SPECIFIED DIMENSIONS ARE IN INCHES TOLERANCES ARE:	THERMOELECTRIC COOLING AMERICA CORP.			
	DECIMALS .XX +/- .XXX +/-	ANGLE +/- FRACTION +/-	TC-5300D PWM CONTROLLER GENERAL WIRING DIAGRAM		
FINISH:	MATERIAL:	DRAWN BY: AA	DRAWING # SK171104	REV LEVEL	
		DATE: 11/02/17	SCALE	MASTER: MASTER	
REV	DESCRIPTION	Date	APPROVED	SHEET	